



HEIDENHAIN



Touch Probes

For Machine Tools

Touch probes for machine tools

Touch probes from HEIDENHAIN were conceived for use on machine tools—in particular milling machines and machining centers. Touch probes help to reduce setup times, increase machine usage time, and improve the dimensional accuracy of the finished workpieces. Setup, measuring, and monitoring functions can be performed manually or—in conjunction with most CNC controls—under program control.

Workpiece measurement

HEIDENHAIN offers **TS triggering touch probes** for workpiece measurement right on the machine. The probe is inserted in the tool holder either manually or by the tool changer. They enable you to use the probing functions offered by your NC control to automatically or manually perform the following functions:

- Workpiece alignment
- Setting presets
- Workpiece measurement
- Digitizing or inspecting 3-D surfaces

Tool measurement

Successful series production hinges on the prevention of scrap or rework and the attainment of consistently good workmanship. The tool is a decisive factor here. Wear or tool breakage that goes undetected for extended periods, especially during unattended operation, result in defective parts and unnecessarily increase costs. Therefore, exact measurement of tool dimensions and periodic control of wear are absolutely essential. For tool measurement on the machine, HEIDENHAIN offers the TT touch probes and the TL laser systems.

With the **TT triggering touch probes**, the contact plate is deflected from its rest position, sending a trigger signal to the NC control, during probing of the stationary or rotating tool.

The **TL laser systems** operate without any contact. A laser beam probes the length, diameter or contour of the tool. Special measuring cycles in the NC control evaluate the information.

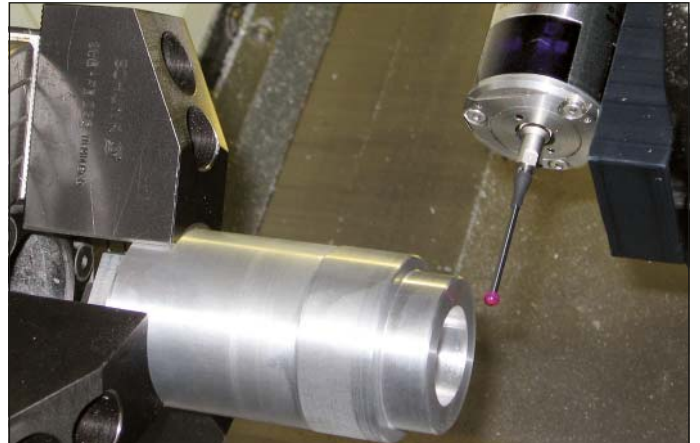

Contents

| | | |
|---|---|-----------|
| Touch probes from HEIDENHAIN | | |
| Experience and profile | | 4 |
| Application examples | Aligning the workpiece and setting the preset | 6 |
| | Workpiece measurement | 7 |
| | Tool measurement with TT touch probes | 8 |
| | Tool measurement with TL laser systems | 9 |
| Workpiece measurement | | |
| TS touch probes | Selection guide | 10 |
| | Principle of function | 12 |
| | Mounting | 18 |
| | Probing | 21 |
| | Specifications | 24 |
| | Tool measurement | |
| Selection guide | | 30 |
| TT touch probes | Principle of function | 33 |
| | Mounting | 34 |
| | Probing | 35 |
| | Specifications | 36 |
| TL laser systems | Components | 39 |
| | Mounting | 40 |
| | Probing | 42 |
| | Specifications | 44 |
| Electrical connection | | |
| Voltage supply | | 50 |
| Interfaces | TS and TT touch probes | 51 |
| | TL laser systems, DA 301 TL | 53 |
| Connection to CNC controls | | 55 |
| Cables and connecting elements, pin layout | | 57 |

Experience and profile

HEIDENHAIN has been developing touch probes for workpiece and tool measurement on machine tools for over 30 years now. It has set standards, for example, with

- the wear-free optical sensor,
- the integrated cleaning flushing/blowing feature for cleaning the measuring point,
- the SE 540—the first transceiver unit capable of being fully integrated into the spindle housing, and
- the collision protection for the TS 460 touch probe.

Of course, many years of experience in continuous development have contributed to these achievements. Numerous improvements make working with the touch probes easier, more reliable, and ultimately more efficient for the operator.

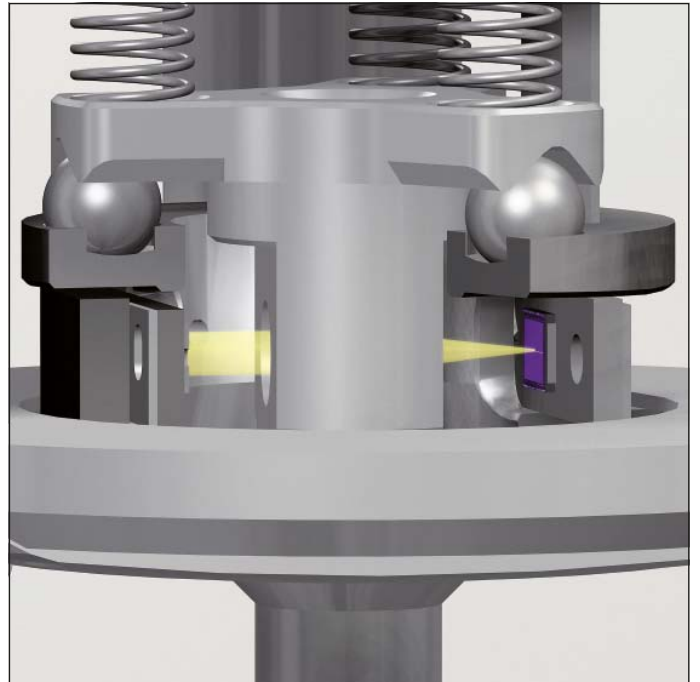

Wear-free optical sensor

Because the optical sensor is free of wear, it is able to provide the specified probing repeatability even after a large number of probe measurements (over 5 million switching cycles). This means that touch probes from HEIDENHAIN are excellently suited for grinding machines. The optical sensor features an optimized lens system and an integrated preamplifier for stable output signals.

Reliable measurement results

Clean measuring points are a prerequisite for high process reliability. That is why all TS workpiece touch probes from HEIDENHAIN have blower/flusher jets for cleaning the workpiece, either with coolant or compressed air.



Collision protection and thermal decoupling (option for TS 460)

Collision protection is a major topic at HEIDENHAIN. The touch probes feature a large deflection path and offer additional safety with rated breaking points in the stylus or the connecting pin to the probe contact. For expanded collision protection to include the touch probe housing of the TS 460, HEIDENHAIN offers an optional mechanical adapter between the touch probe and the taper shank. In the event of a light collision against a fixture or workpiece, the touch probe can absorb the shock. At the same time, the integrated switch deactivates the ready signal, and the control stops the machine.

Furthermore, the collision protection adapter functions as a thermal decoupler. This protects the touch probe from being heated by the spindle.



Worldwide presence

In addition to the technical advantages, HEIDENHAIN and its subsidiaries also offer reliable service in over 50 countries; regardless of the country of destination for a machine with a touch probe, HEIDENHAIN is there to support you on site.



Application examples

Aligning the workpiece and setting the preset

Workpiece alignment

Exact workpiece alignment parallel to the axes is particularly important for partially machined workpieces to ensure that existing reference surfaces are in an accurately defined position. With the TS touch probes from HEIDENHAIN, you can avoid this time-consuming procedure and do without the clamping devices otherwise required:

- The workpiece is clamped in any position.
- The touch probe ascertains the workpiece misalignment by probing a surface, two holes, or two studs.
- The CNC compensates for the misalignment by rotating the coordinate system. It is also possible to compensate for it by rotating the table.

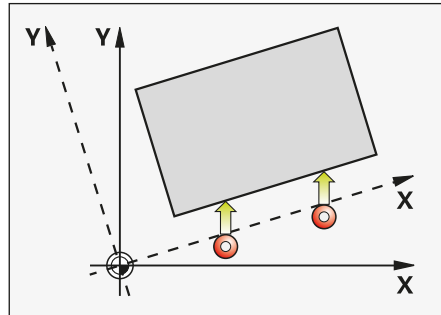

Compensating for misalignment through a basic rotation of the coordinate system

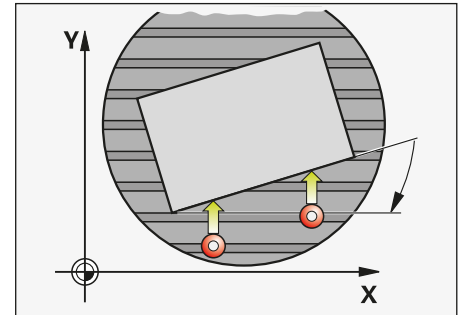

Compensating for misalignment by rotating the table

Setting a preset

Programs for workpiece machining are based on presets. Finding this point quickly and reliably with a workpiece touch probe reduces nonproductive time and increases machining accuracy. If probing functions are available on the CNC, the TS touch probes from HEIDENHAIN make it possible to set presets automatically.

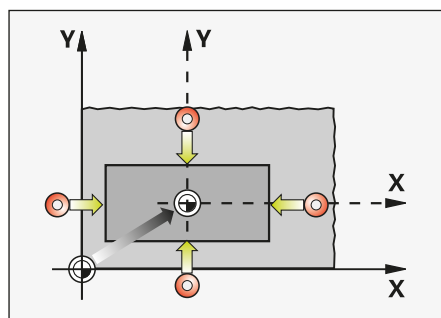
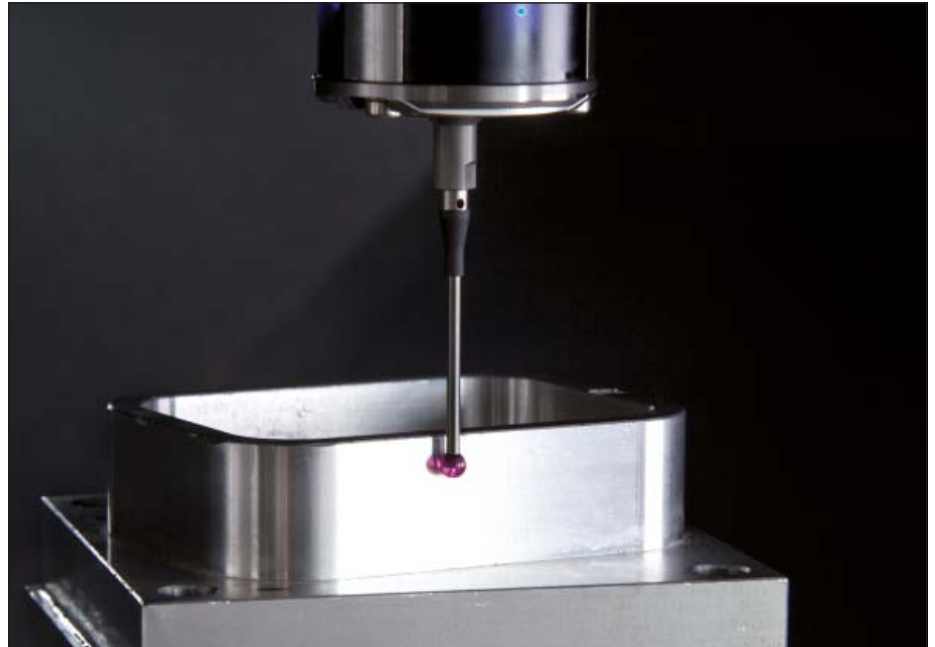

Center of a rectangular stud

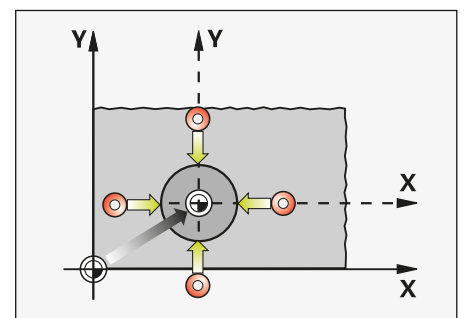

Center of a circular stud

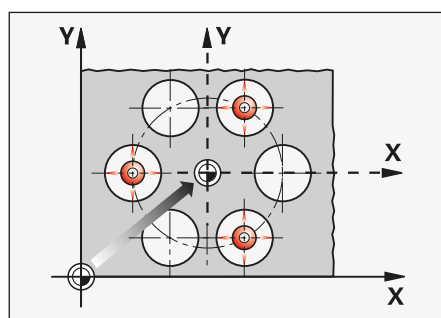

Center of a bolt hole circle

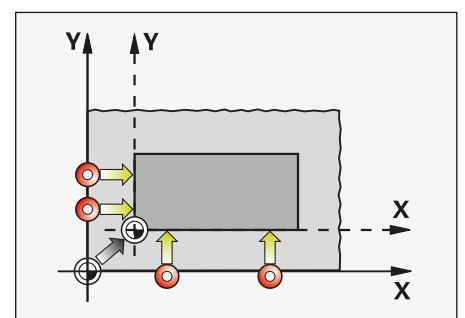

Outside corner

Workpiece measurement

Touch probes from HEIDENHAIN are suited for program-controlled workpiece measurement between two machining steps. The resulting position values can be used for tool wear compensation. When the workpiece is done, the measured values can document dimensional accuracy or serve to record machining trends. The CNC can output the measurement results through the data interface.

With the aid of external software—for example, FormControl (software package from Blum-Novotest) or digitizing software—you can digitize models or measure free-form surfaces right in the machine tool. In this way you can detect machining errors immediately and correct them without reclamping. Thanks to their mechanical design and wear-free optical switch, TS touch probes from HEIDENHAIN are ideal for this purpose.

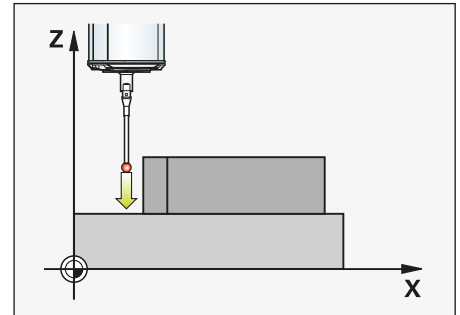
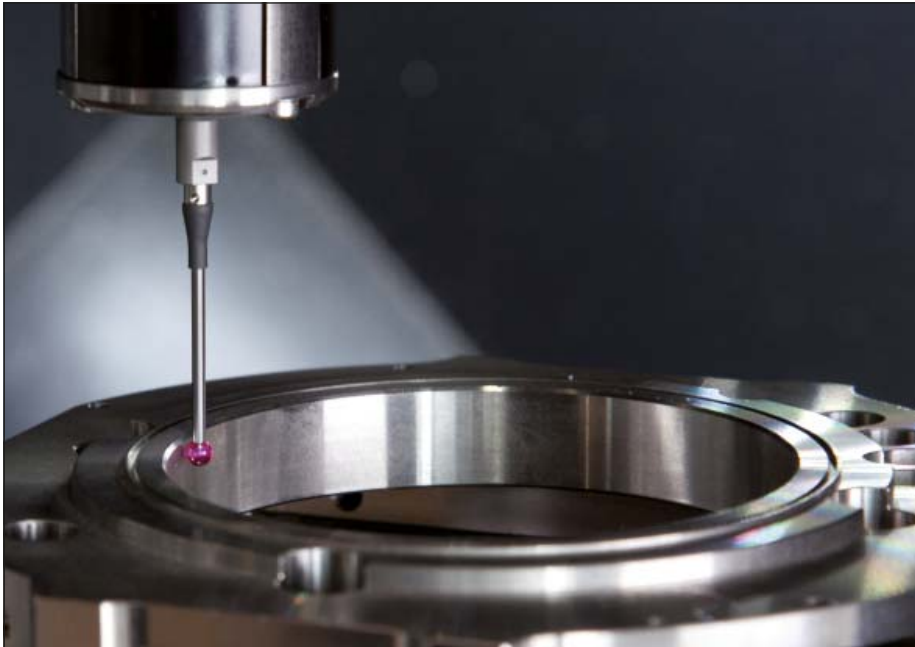

Measuring individual positions in an axis

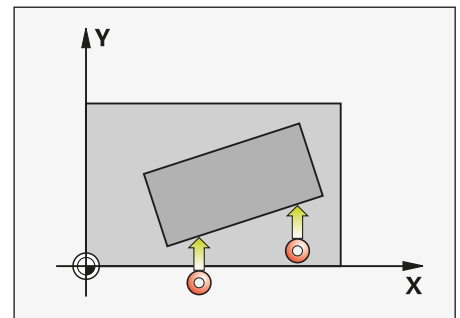

Measuring the angle of a line

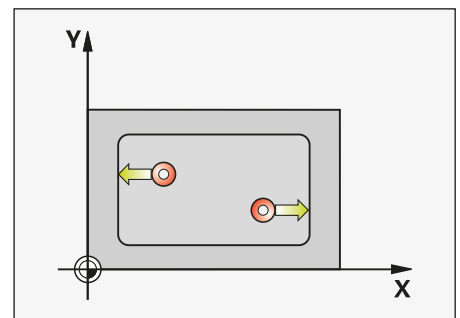

Length measurement

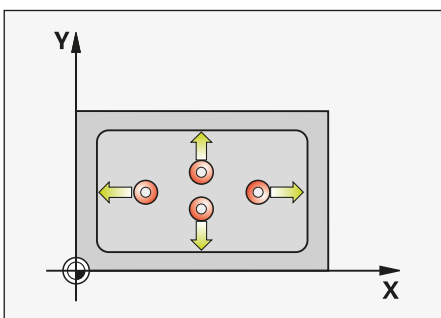

Measuring a rectangular pocket

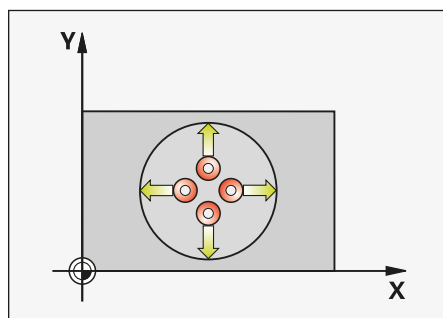

Circular pocket/hole measurement

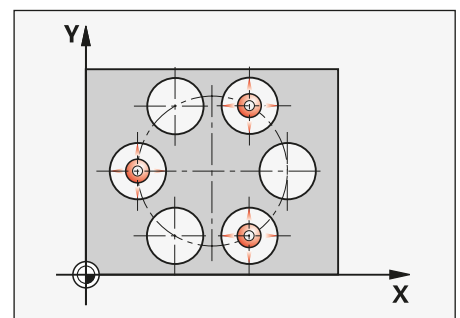

Measuring a bolt hole circle

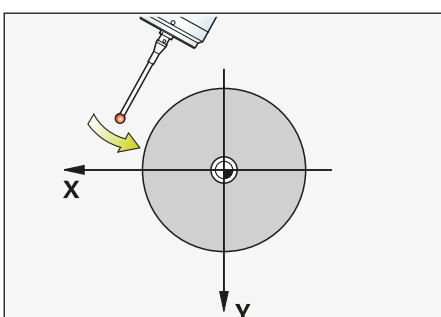

Measuring a diameter

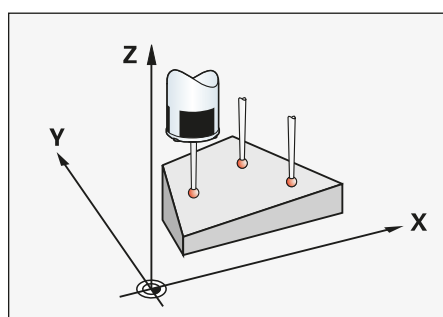

Measuring the angle of a plane

Tool measurement with TT touch probes

Consistently high machining accuracy requires an exact measurement of tool data and cyclical inspection of tool wear. The TT tool touch probes measure almost any type of tool right on the machine. For milling cutters, they can be used to

measure length and diameter, including the dimensions of individual teeth. The CNC automatically saves the measurement results in the tool memory for use with the part program.

Using a cuboid probe contact, you can also measure turning tools and check them for breakage. For effective tool-tip radius compensation you only need to add the cutter radius to your entries in the CNC.

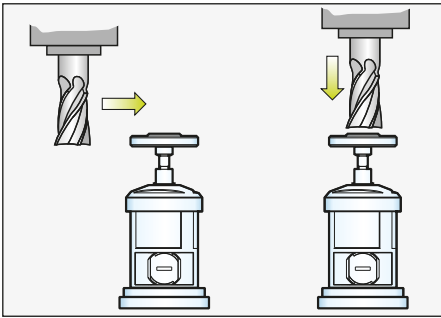

Tool length and radius measurement with stationary or rotating spindle

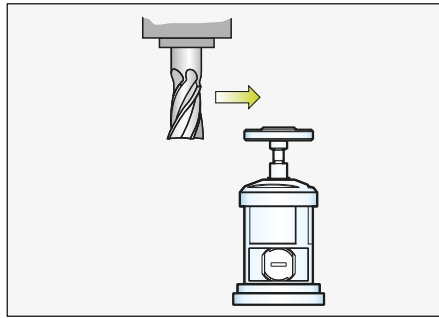

Individual tooth measurement, e.g., for inspecting indexable inserts (not for breakable materials)

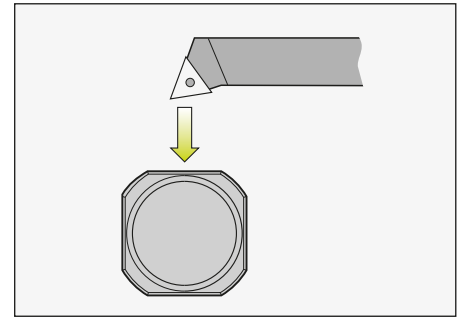

Turning tool measurement

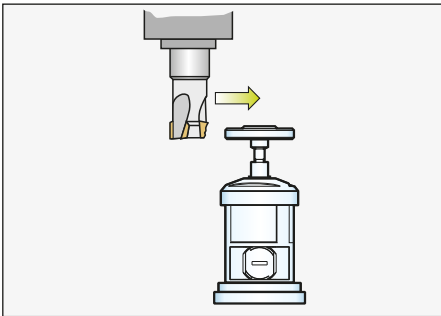

Tool wear measurement

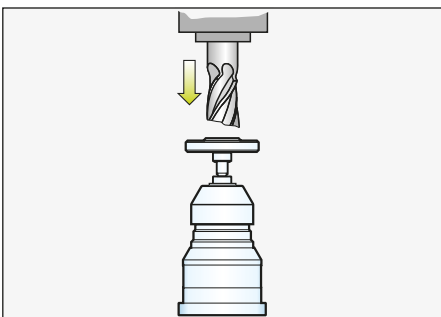

Tool breakage monitoring



Tool measurement with TL laser systems

Tool measurement with the TL laser systems offers special benefits. The contact-free measuring method by laser beam enables you to check even the smallest tools rapidly, reliably, and without collision.

The TL laser systems also have no trouble handling modern cutting tools made of hard, brittle materials.

Because the tool is measured at rated speed, errors on the tool, spindle, and holder are detected and corrected directly.

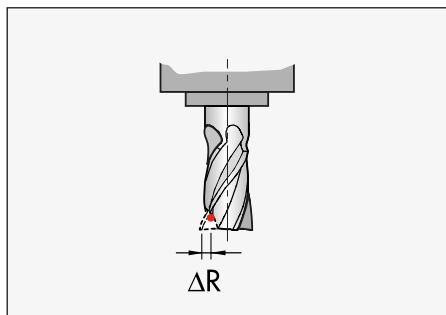

Tool radius measurement, detection of tooth breakage

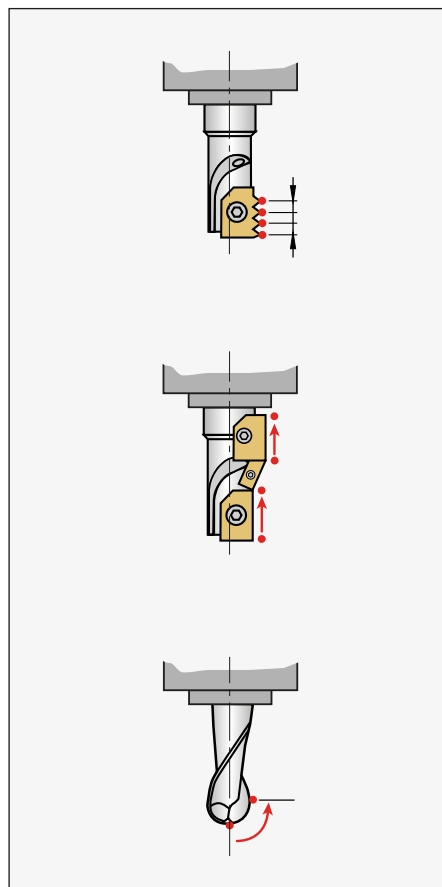
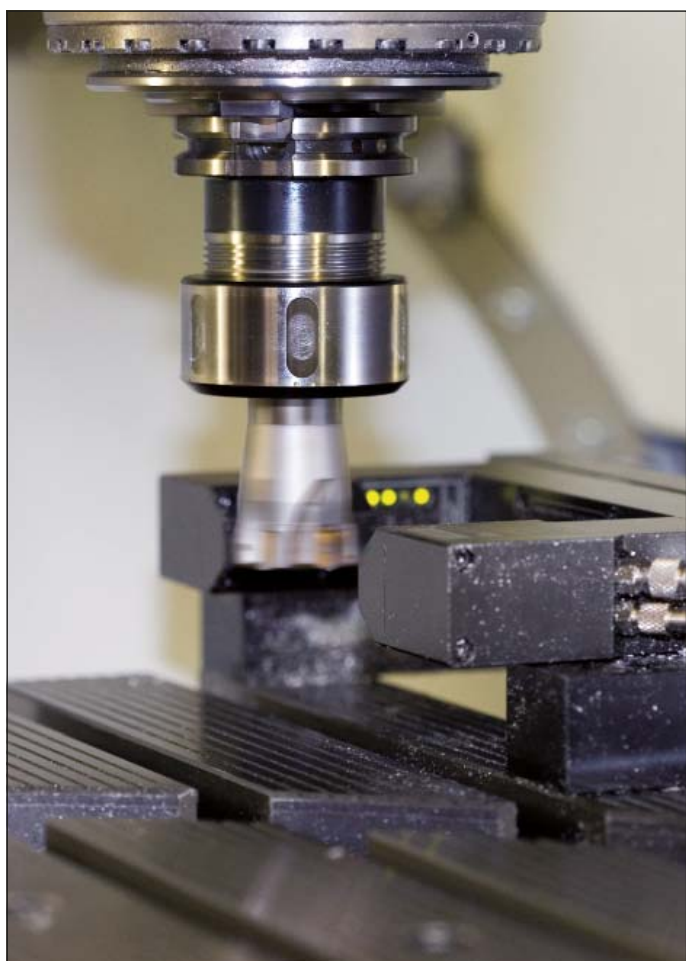

Single tooth and shape inspection

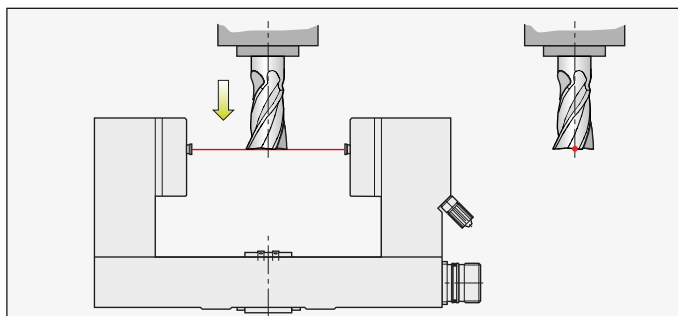

Tool length measurement

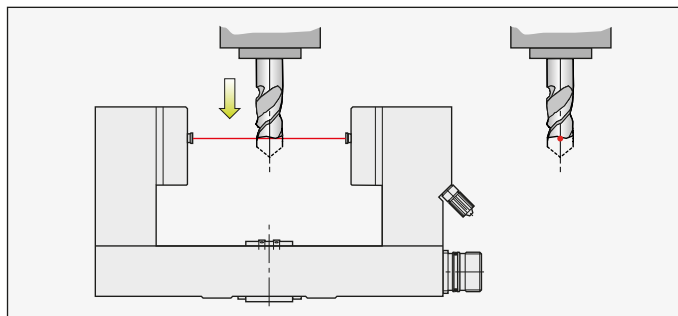

Detection of tool breakage

Selection guide

The TS workpiece touch probes from HEIDENHAIN help you perform setup, measuring, and inspection functions directly on the machine tool.

The stylus of a TS touch trigger probe is deflected upon contact with a workpiece surface. At that moment the TS generates a trigger signal that is transmitted to the control either by cable or by an infrared or radio signal. The control simultaneously saves the actual position values as measured by the machine axis encoders and uses this information for further processing.

| | TS workpiece touch probes | | |
|-----------------------------|--|--|--------------------------------|
| | TS 460 | TS 642 | TS 740 |
| Area of application | Machining centers; milling, drilling, and boring machines; lathes with automatic tool change | | |
| Signal transmission | Radio or infrared | Infrared | Infrared |
| Suitable SE | SE 660, SE 540 ¹⁾ , SE 642 ¹⁾ , SE 661 | SE 540, SE 642, SE 660 | SE 540, SE 642 |
| Probe repeatability | 2 σ \leq 1 μ m | | 2 σ \leq 0.25 μ m |
| Voltage supply | Batteries, rechargeable or nonrechargeable | Batteries, rechargeable or nonrechargeable | |
| Interface to control | HTL via SE | | |
| Cable outlet | – | | |

¹⁾ Only for infrared transmission

HEIDENHAIN touch probes are available in various versions for workpiece measurement on machining centers; milling, drilling, and boring machines; and on CNC lathes:

Touch probes with **wireless signal transmission** for machines with manual tool changer:

TS 460 – New generation standard touch probe for radio and infrared transmission, with compact dimensions

TS 642 – Infrared transmission, activation by switch in the taper shank; compatible with previous generations of touch probes

TS 740 – High probe accuracy and repeatability, low probing force, with infrared transmission

Touch probes with **cable connection for signal transmission** for machines with manual tool change, as well as for grinding machines and lathes:

TS 150 – New generation, axial or radial cable

TS 260 – New generation, axial or radial cable

TS 248 – New generation, axial or radial cable, with reduced deflection force



| | TS 248 TS 260 | TS 150 |
|--|---|-------------------|
| | Milling, drilling, and boring machines with manual tool change, lathes, and grinding machines | Grinding machines |
| | Cable | |
| | – | |
| | $2\sigma \leq 1\ \mu\text{m}$ | |
| | 15 V to 30 V DC | via UTI 150 |
| | HTL and floating switching output | |
| | Axial or radial | |

| Contents | | |
|------------------------------|---|----|
| Principle of function | Sensor | 12 |
| | Accuracy | 13 |
| | Signal transmission | 14 |
| | Range of transmission | 16 |
| | Optical status indicator | 17 |
| Mounting | TS workpiece touch probes | 18 |
| | Transceiver unit | 20 |
| Probing | General information | 21 |
| | Collision protection and thermal decoupling | 22 |
| | Styli | 23 |
| Specifications | TS 150, TS 248, and TS 260 | 24 |
| | TS 460, TS 642, and TS 740 | 26 |
| | SE 660, SE 642, and SE 540 | 28 |



Principle of function

Sensor

TS 150, TS 248, TS 260, TS 460, TS 642

These touch probes from HEIDENHAIN operate with an optical switch as sensor. A lens system collimates the light generated from an LED and focuses it onto a differential photocell. When the stylus is deflected, the differential photocell produces a trigger signal.

The stylus of the TS is rigidly connected to a plate integrated in the probe housing on a three-point bearing. The three-point bearing ensures the physically ideal rest position.

Thanks to the non-contacting optical switch, the sensor is free of wear. In this way, HEIDENHAIN touch probes ensure high long-term stability with a constant probe repeatability even after very many measuring processes, as for example with in-process applications.

TS 740

The TS 740 uses a high-precision pressure sensor. The trigger pulse is obtained through force analysis. The forces acting during probing are processed electronically. This method provides extremely homogeneous probe accuracy over 360°.

With the TS 740, the deflection of the stylus is measured by several pressure sensors that are arranged between the contact plate and the probe housing. When probing a workpiece, the stylus is deflected and a force acts on the sensors. The signals generated are processed, and the trigger signal is produced. The relatively low probing forces provide high probe accuracy and repeatability, while offering precise trigger characteristics in all directions.

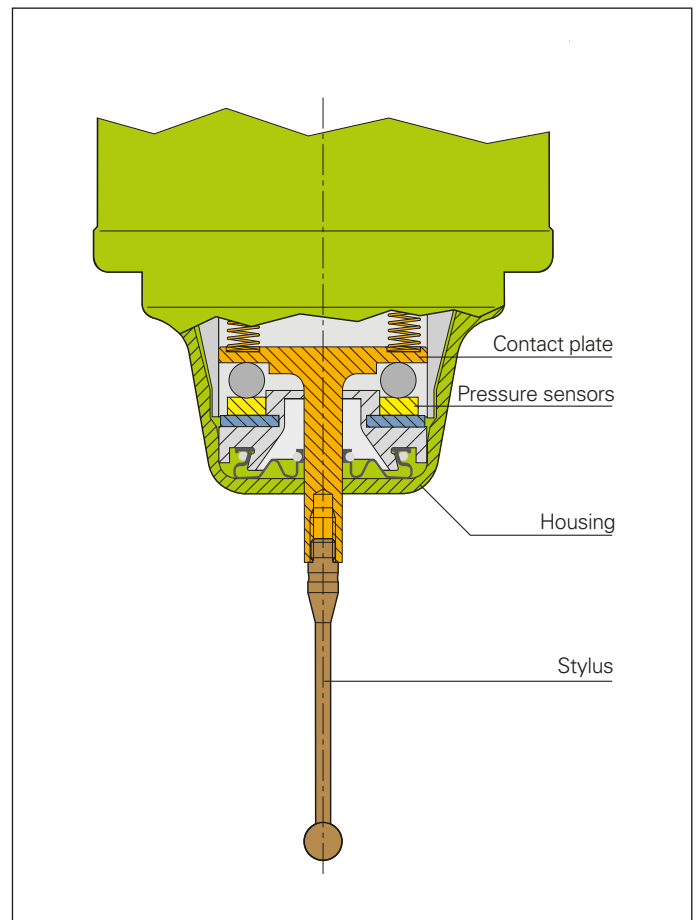
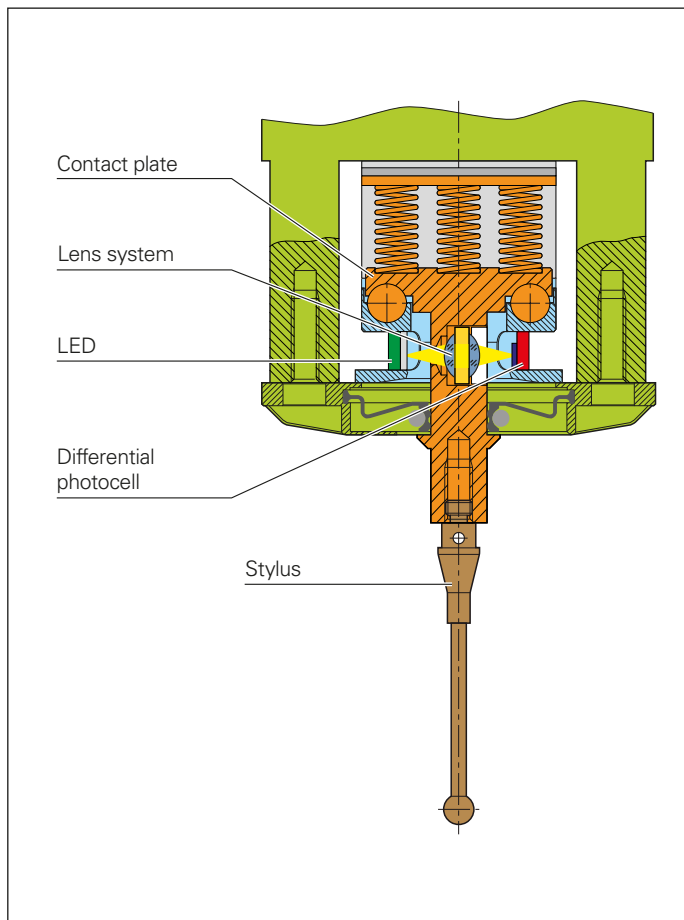

Accuracy

Probe accuracy

The probe accuracy specifies the error resulting from probing a test component from **various directions**.

The probe accuracy also involves the effective ball radius. The effective ball radius is calculated from the actual ball radius and the stylus deflection required to produce the trigger signal. Stylus bending is also taken into consideration.

The probe accuracy of a touch probe is measured at HEIDENHAIN on precision measuring machines. The reference temperature is 22 °C, and the stylus used is the T404 (40 mm length, 4 mm ball diameter).

The **TS 740** triggering touch probe is particularly characterized by high probe accuracy and repeatability. These features, together with the low probing force of the TS 740, make it suitable for very demanding measuring tasks on machine tools.

Probe repeatability

Probe repeatability is the dispersion of the results derived from repeated probing **from the same direction**.

Influence of probe styli

Stylus length and stylus material directly influence the trigger characteristics of a touch probe. Styli from HEIDENHAIN ensure a probe accuracy of better than $\pm 5 \mu\text{m}$.

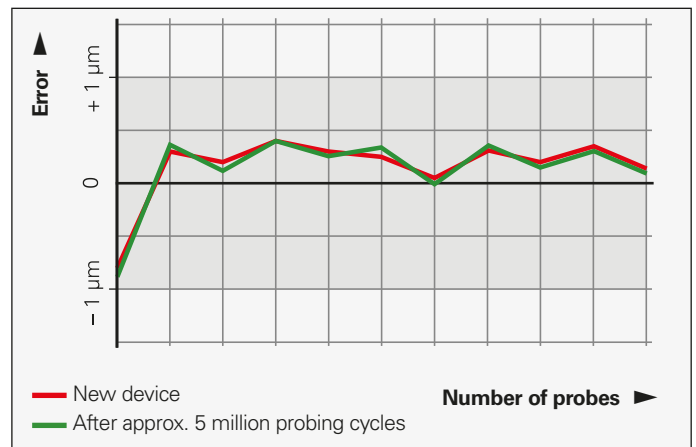

Typical probe repeatability curve of a TS 2xx/4xx/6xx touch probe: Results of repeated probing from one direction at a defined spindle orientation

| HEIDENHAIN | | Messprotokoll Calibration Chart | | TS 740 | |
|---|--|---|--|-------------------|--|
| Antastabweichung / Probe accuracy grade | | X; Y-Achse/Axis: $\pm 0,71 \mu\text{m}$ | | Id.Nr.: 573757-01 | |
| Antast-Reproduzierbarkeit / Probe repeatability | | X; Y-Achse/Axis: $2\sigma 0,15 \mu\text{m}$ | | S.Nr.: 20492261G4 | |
| | | Antastgeschwindigkeit / Probe velocity: | | 1 mm/s | |
| | | Bezugstemperatur / Reference temperature: | | 22°C \pm 1°C | |

| | |
|---|--|
| Die Messkurve zeigt die Mittelwerte aus 10 Antastungen pro Antastrichtung. | The error curve shows the mean values from ten measurements per probe direction. |
| Antastabweichung $\Delta S = S_p - S_M$ | Probe accuracy grade $\Delta S = S_p - S_M$ |
| ($S_p = (S_{M \max} + S_{M \min})/2$, $S_M =$ Schallposition des Prüflings) | ($S_p = (S_{M \max} + S_{M \min})/2$, $S_M =$ Trigger point of the test component) |
| Anzahl der Antastrichtungen: 6 | Number of probe directions: 6 |

| | | | |
|---|--------------------------------------|---|---|
| Hersteller-Prüfzertifikat (DIN 55 350-18-4.2.2) | | Manufacturer's Inspection Certificate (DIN 55 350-18-4.2.2) | |
| Dieses Gerät wurde unter strengen HEIDENHAIN-Qualitätsnormen hergestellt und geprüft. | | This unit has been manufactured and inspected in accordance with the stringent quality standards of HEIDENHAIN. | |
| Genauigkeitsklasse $\pm 1,0 \mu\text{m}$ | Kalibriernormal Laser-Interferometer | Accuracy grade $\pm 1,0 \mu\text{m}$ | Calibration standard Laser interferometer |
| Antast-Reproduzierbarkeit $2\sigma 0,25 \mu\text{m}$ | Kalibrierzeichen 4120 PTB 02 | Probe repeatability $2\sigma 0,25 \mu\text{m}$ | Calibration mark 4120 PTB 02 |

Signal transmission

Signal transmission by cable

The TS 150, TS 260, and TS 248 touch probes feature a plug-in cable that both provides the power supply and transmits the trigger signal.

When the TS 260 is used for milling, drilling, and boring machines, the machine operator inserts the touch probe by hand into the spindle. The spindle must be locked before the touch probe can be inserted (spindle stop). The CNC's probing cycles can run with both vertical and horizontal spindles.

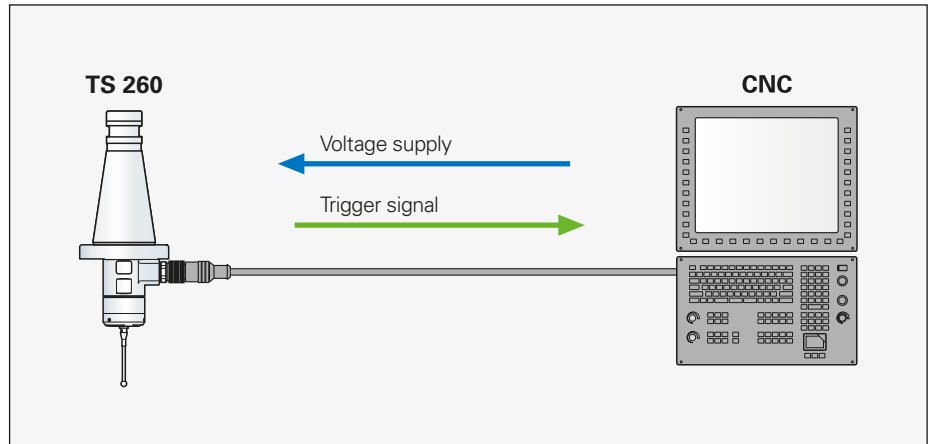

Wireless signal transmission

The signals are transmitted from wireless touch probes to the SE transceiver unit via

- radio or infrared for the **TS 460**
- infrared for the **TS 642, TS 740**

This makes these touch probes ideal for use on machines with automatic tool changers.

The following transceiver units are available:

- **SE 660, SE 661** for radio and infrared transmission; shared SE for TS 460 and TT 460
- **SE 540** only for infrared transmission, for integration in the spindle head
- **SE 642** only for infrared transmission, shared SE for TS and TT

The SE 660 and SE 661 communicate with the TS 460 and TT 460. The SE 540 and SE 642 can be used in any combination with the TS 4xx, TS 642, and TS 740 touch probes.

The following signals are transmitted: The **start signal** activates the touch probe. The touch probe indicates operability with a **ready signal**. A deflection of the stylus produces the **trigger signal**. If the TS 460/TS 642/TS 740's battery capacity falls below 10 %, it transmits a **battery warning**. The falling edge of the start signal switches the touch probe off again.

| | SE 660 | SE 661 | SE 540 | SE 642 |
|--------|----------------|--------|----------|----------|
| TS 460 | Radio/infrared | | Infrared | Infrared |
| TS 642 | Infrared | – | Infrared | Infrared |
| TS 740 | – | | Infrared | Infrared |

Signal transmission types and combinations of TS and SE

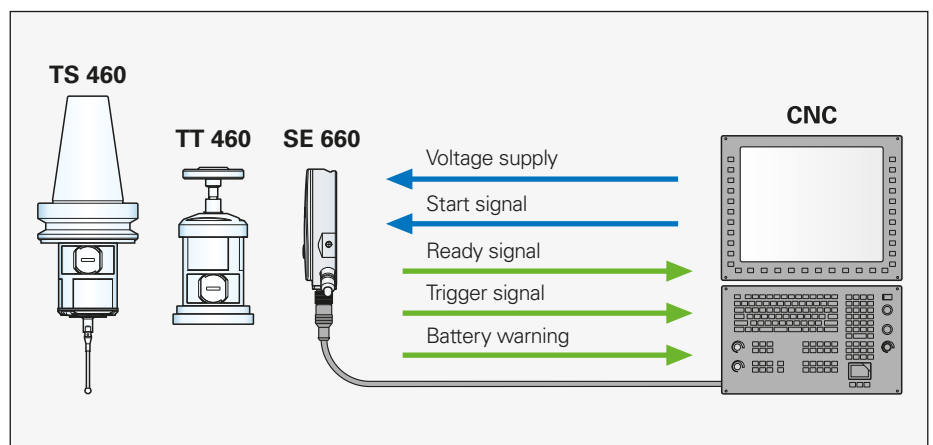

Infrared transmission

Infrared transmission is ideal for compact machines with closed working spaces. Thanks to reflection, the signal is received even in otherwise inaccessible locations. Infrared transmission has a range of up to 7 meters. The carrier frequency method applied by the TS 460 offers very strong noise immunity with extremely short transmission times of approx. 0.2 ms for the trigger signal. This permits exact measurement results, regardless of the probing velocity.

Radio transmission (only TS 460, TT 460)

Radio transmission is used mainly for large machine tools. The range is usually 15 m, but in practice much larger ranges are possible under ideal circumstances. Radio transmission operates in the free ISM band at 2.4 GHz and offers 16 channels. The transmission times for the trigger signal are approx. 10 ms. Each touch probe is uniquely addressed.

Hybrid technology: Signal transmission via radio or infrared signals (only TS 460, TT 460)

The dual signal transmission of the TS 460 combines the advantages of radio waves (high range and large amounts of data) with infrared signals (highest accuracy and fast signal transmission). You can switch between three possibilities: pure infrared transmission (factory default setting), pure radio transmission, or mixed operation. This offers the following benefits:

- You save time per measuring cycle without sacrificing accuracy if you activate the touch probe by radio while it's still in the tool changer (i.e., outside of the working space). The measurement is made with fast—and therefore more accurate—infrared transmission.
- You can operate one version of a touch probe on different types of machines (milling machines, lathes, grinding machines) and on any machine size (from small and enclosed to large and open).

Regardless of whether you work with radio or infrared transmission, you only need one SE 660 or SE 661 transceiver unit.

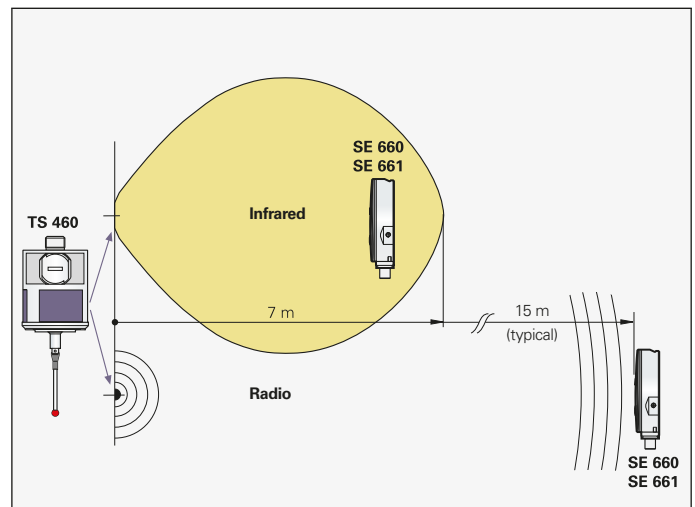
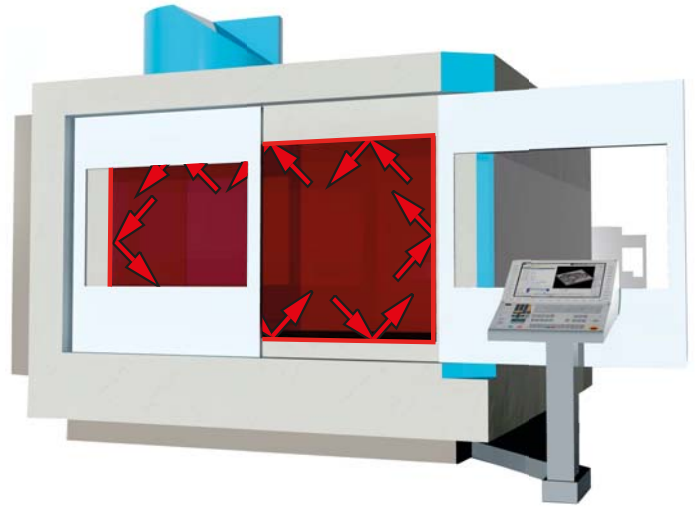

Range of transmission

Infrared transmission

The transmission areas between the SE transceiver unit and the touch probes have a lobe shape. In order to ensure optimum signal transmission in both directions, the transceiver should be mounted so that the touch probe is within this area for all operating positions. If the infrared transmission is disturbed or the signal becomes too weak, the SE notifies the CNC via the ready signal. The size of the transmission area depends on both the touch probe used and on the transceiver being used along with it.

360° transmission range

The LEDs and receiver modules for infrared transmission are distributed in such a way that uniform transmission is available over the entire circumference (360°). This ensures a 360° transmission range for reliable reception without previous spindle orientation.

Angle of transmission

The wireless TS 642 and TS 740 touch probes are available for adaptation to the machine design with a horizontal transmission angle of 0° or +30°. The TS 460 permits communication with the SE 540 in the normal version.

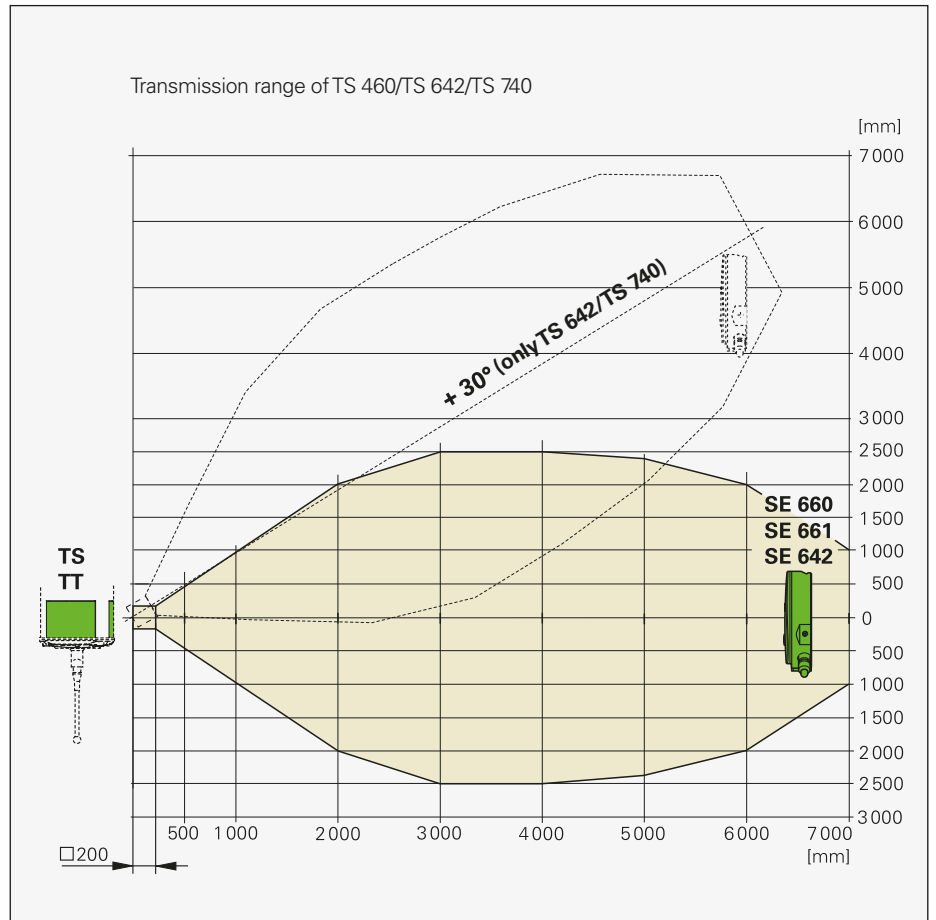

Radio transmission

The TS 460 touch probe's radio transmission depends on direction. The transmission range is typically 15 m, and much larger ranges are possible under optimum conditions.

Transmission signal quality

The signal quality of the infrared or radio transmission is shown on the SE by means of a multicolor LED (see visual status indicator). This makes it immediately clear whether the touch probe is still within the transmission range of the SE.

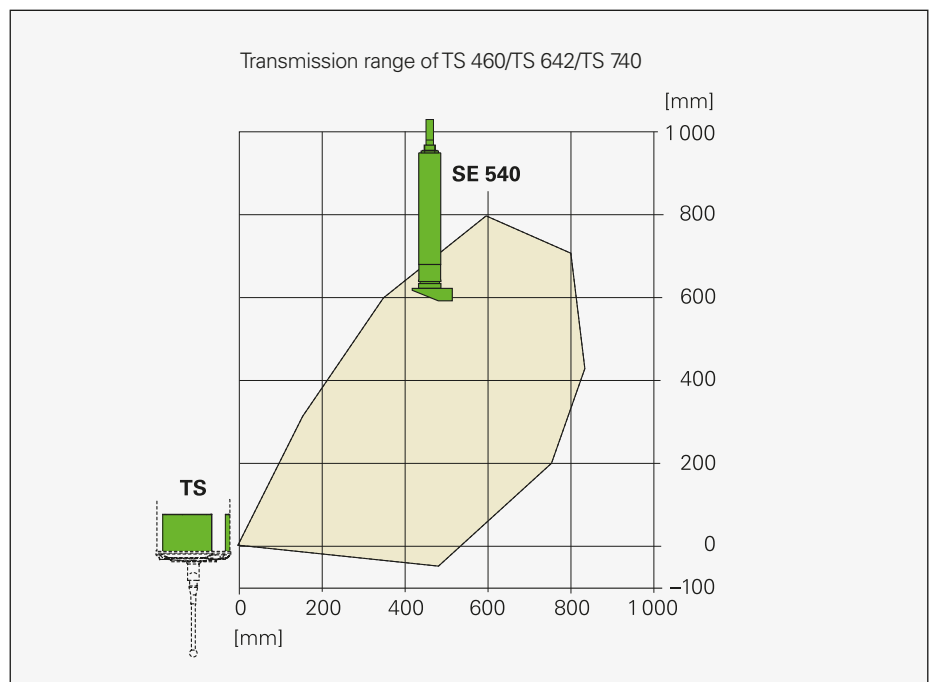

Optical status indicator

Touch probes and transceiver units from HEIDENHAIN are equipped with LEDs that also indicate the respective condition of the output signals (stylus deflection, readiness, etc.). This enables you to check the touch probe status and the transmission distance at a glance and simplifies both installation and operation.

TS touch probes

Multiple LEDs indicating stylus deflection are arranged along the circumference of the TS touch probes so that they are visible from any angle. On wireless versions, these LEDs also show readiness.



SE 540 transceiver unit

The SE 540 transceiver features one multicolor LED indicator that continuously displays the condition of the touch probe (deflection and battery capacity).

SE 642 transceiver unit

The SE 642 features several multicolor LED indicators that, in addition to status indication, also make comprehensive diagnostics possible. They display:

- Standby
- Active touch probe
- Deflection
- Battery capacity
- Quality of infrared transmission
- Disturbances and faults

SE 660 and SE 661 transceiver units

In addition to having LEDs, the SE 660 for radio and infrared transmission also features segment and bar displays. These provide comprehensive information on commissioning, operation, and diagnostics:

- Standby
- Active touch probe
- Deflection
- Battery capacity
- Quality of the radio or infrared signal
- Connection setup
- Channel utilization for radio signal
- Collision and faults
- Channel
- Mode of operation

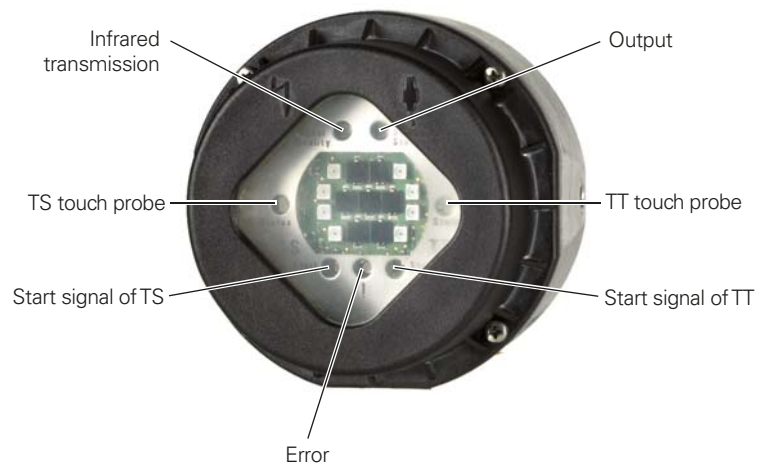

Mounting

TS workpiece touch probes

The TS workpiece touch probes from HEIDENHAIN are suitable for use on all sorts of machine tools and offer all the necessary mounting options:

- **Clamping shanks** for machining centers as well as for milling, drilling, and boring machines
- **Tool holders** for special solutions
- **Fastening screw threads** for individual mounting solutions (e.g., on lathes or grinding machines)



Taper shanks

The TS workpiece touch probes are inserted directly into the machine spindle. An assortment of taper shanks is delivered with the TS for use with various clamping systems. A complete selection is listed here. All other commercially available taper shanks are available upon request.

DIN 69871
Taper

| Taper | D |
|------------|-----|
| SK-A 40 | M16 |
| SK-A 45 | M20 |
| SK-A 50 | M24 |
| SK-AD/B 30 | M12 |
| SK-AD/B 40 | M16 |
| SK-AD/B 45 | M20 |
| SK-AD/B 50 | M24 |
| SK-AD/B 60 | M30 |

DIN 2080
Taper

| Taper | D |
|---------|-------------|
| SK-A 40 | M16 |
| SK-A 45 | M20 |
| SK-A 50 | M24 |
| SK-A 50 | UNC 1.000-8 |

JIS B 6339
Taper

| Taper | D |
|-------|-----|
| BT 30 | M12 |
| BT 40 | M16 |
| BT 50 | M24 |

DIN 69893
Taper

| |
|-----------|
| HSK-E 25 |
| HSK-E 32 |
| HSK-A 40 |
| HSK-E 40 |
| HSK-A 50 |
| HSK-E 50 |
| HSK-A 63 |
| HSK-B 63 |
| HSK-F 63 |
| HSK-A 80 |
| HSK-A 100 |

ASME B5.5
Taper

| Taper | D |
|-------|-------------|
| SK 40 | UNC 1x000-8 |
| SK 50 | UNC 1x000-8 |

Tool holders

If you use other shanks, the touch probes can be held by standardized straight shanks in commercially available collet chucks. Straight shanks are available for the following tool holders:

- Weldon or shrink-fit chuck as per DIN 6535-HB16
- Whistle notch in accordance with DIN 6535-HE16

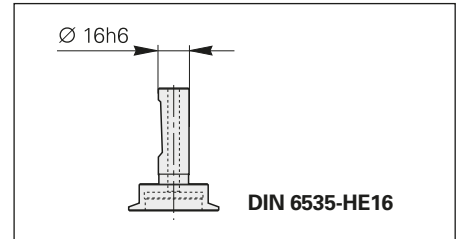
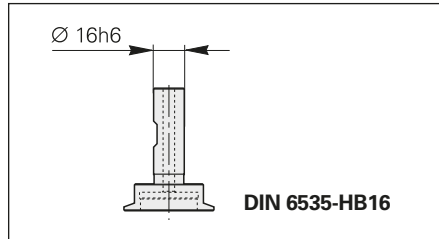

Threaded mounting hole

The TS touch probes can also be supplied without taper shanks. In this case, a thread is used for mounting.

- M16x1 for TS 150
- M28x0.75 for TS 260/TS 248
- M12x0.5 for TS 460/TS 444
- M30x0.5 for TS 642/TS 740

Accessories:

Coupling joint for TS 260/TS 248

ID 643089-01

The M22x1 coupling joint with external thread is used for simple attachment of the TS 260/TS 248 to a machine element or mounting base—or to lathes or grinding machines via a tilting device, for example. With the aid of the coupling joint, the TS can also be rotated as desired on a rigid fastening element. This allows you, for example, to align the TS with an asymmetric or cuboid probe contact exactly parallel to the machine axes.

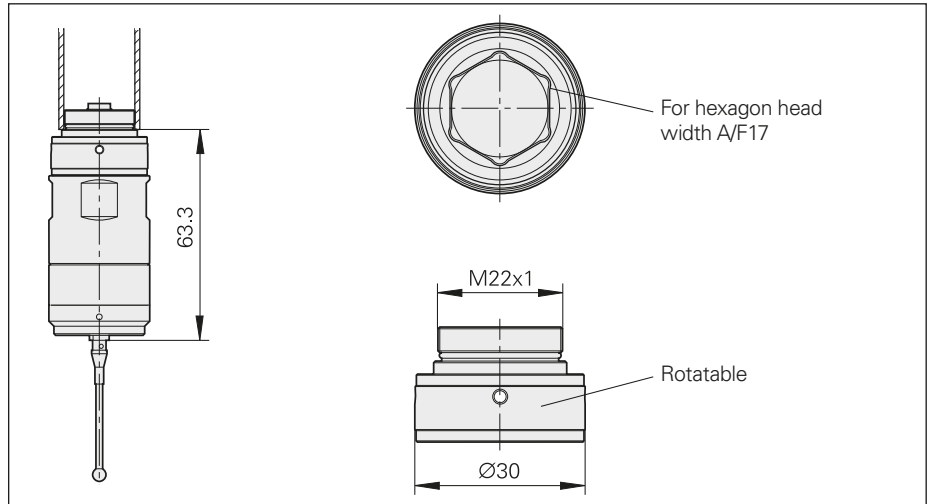

M12/M30 threaded ring

ID 391026-01

The threaded ring serves to adapt the taper shanks and tool holders with an M30 thread to the TS 4xx (M12x0.5)

Mounting wrench

For mounting a taper shank on the TS 460: ID 1034244-01

TS 740/TS 642: ID 519833-01

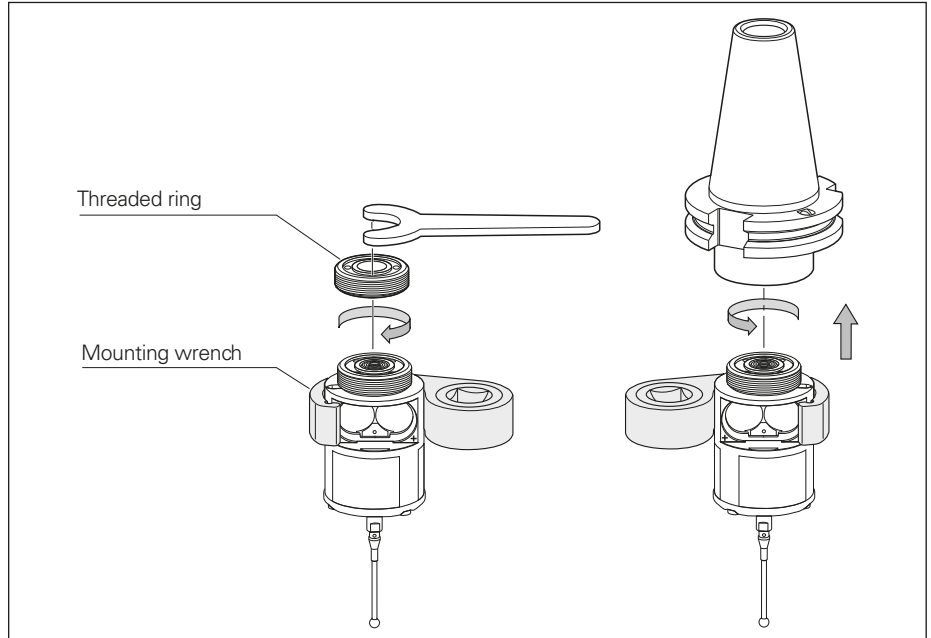

Mounting base for TS 150

ID 1184715-10 axial

ID 1213408-10 radial

The mounting base with integrated cable outlet is required for installation of the TS 150.

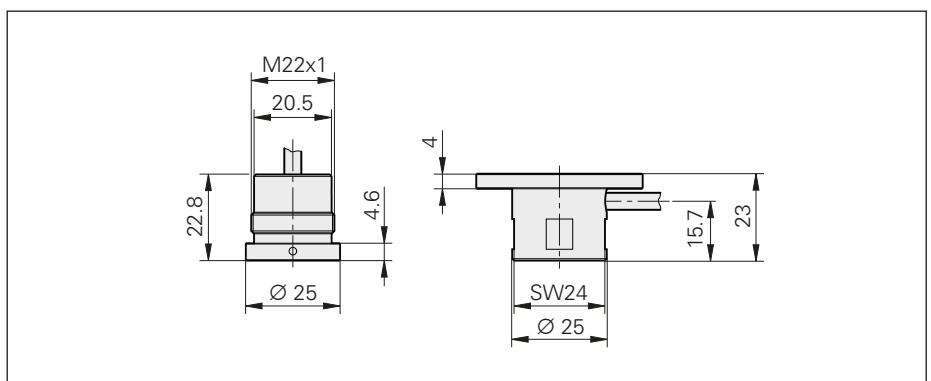

Transceiver unit

The SE transceiver for infrared transmission should be mounted so that it remains within the transmission range of the touch probe over the machine's entire range of traverse. For radio transmission, sufficient clearance from sources of interference must be ensured. The lateral clearance to metal surfaces must be at least 60 mm.

SE 660, SE 661, and SE 642 transceiver units

Thanks to their high IP67 degree of protection, these units can be mounted as desired in the working space and can be exposed to coolant. If the SE is to be used both for a workpiece touch probe and the TT 460 tool touch probe, it must be ensured during mounting that it can communicate with both touch probes.

It is fastened from the side by two M5 threaded holes. Appropriate holders are available as accessories for simple mounting. It is also easily to retrofit.

Accessories

Holder for SE 660 and SE 661 ID 744677-01

The holder for the SE 660 is secured to a machine element via two M4 screws, and the SE is simply clipped in.

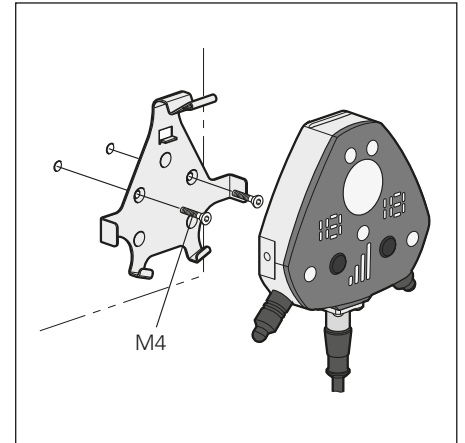
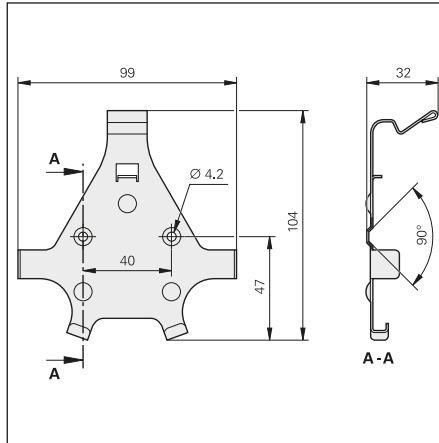
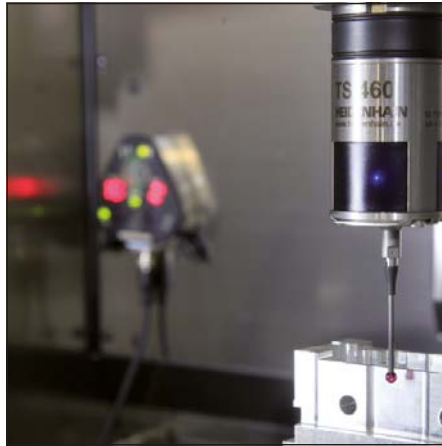

Holder for SE 642

ID 370827-01

SE 540 transceiver unit

The SE 540 is intended for integration into the spindle head. Except for a few cases, for example on machines with quills, this ensures transmission on machines with very large traverse ranges or with swivel heads. The transmission range of the infrared signal is appropriate to the mounting location. Because the SE 540 is always above and to the side of the TS, HEIDENHAIN recommends a +30° transmission angle. The machine must be designed to support the SE 540.

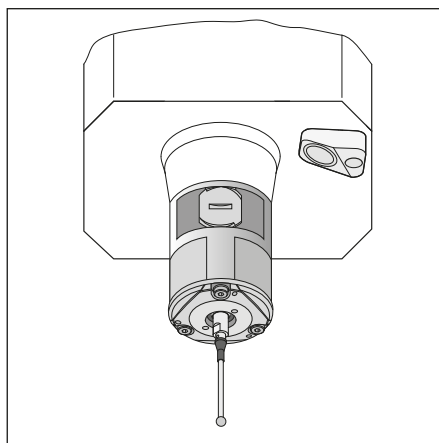
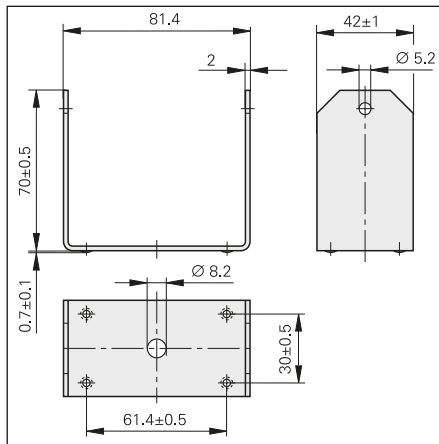

Probing

The workpiece geometry or position is ascertained by the TS workpiece touch probe through mechanical probing. To ensure correct measurement, the workpiece should be free of chips and other foreign matter.

Upon deflection of the stylus, a trigger signal is transmitted to the control. In addition, the deflection is indicated by LEDs on the circumference of the touch probe.



The wireless touch probes feature an integrated **cleaning blower/flusher**: The probing point can be cleaned of loose particles with the aid of compressed air or cooling liquids through jets at the bottom of the probe. Even chip accumulation in pockets is no problem. This allows automatic measuring cycles during unattended operation. The cleaning blower can only work on machines with a compressed-air or cooling fluid duct through the spindle.

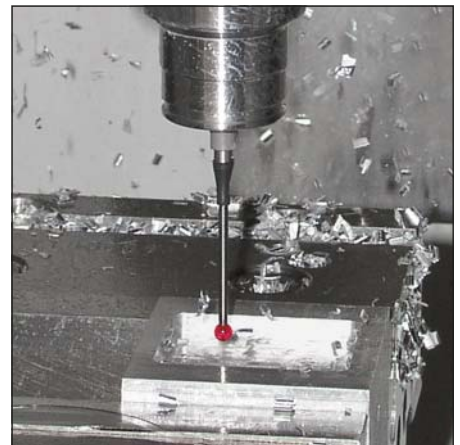

Probing velocity

Signal propagation times in the CNC as well as infrared transmission and especially radio transmission influence the repeatability of the touch probe. Besides the signal propagation time, the permissible stylus deflection must also be considered. The mechanically permissible probing velocity is shown in the specifications.

Deflection of probe contact

The maximum permissible deflection of the stylus is 5 mm in any direction. The machine must stop moving within this distance to avoid damaging the touch probe.

Deflection of the stylus

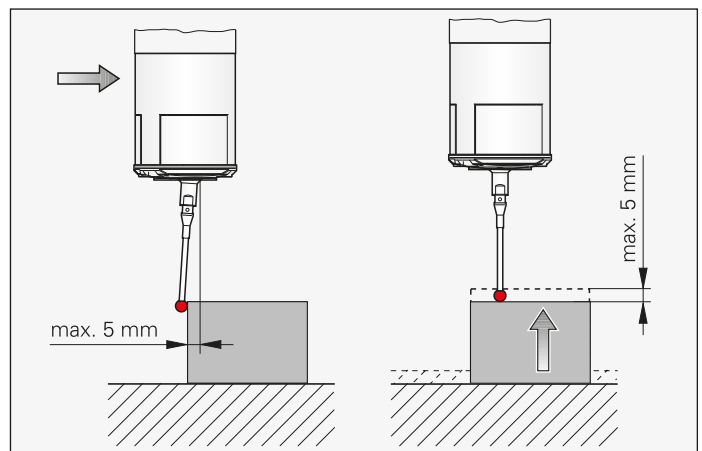

Collision protection and thermal decoupling (option with TS 460)

Mechanical collision protection

A mechanical adapter between the touch probe and taper shank serves as collision protection. The touch probe thus gives slightly during light collisions of its housing against a fixture or workpiece. An integrated switch simultaneously deactivates the ready signal, and the control stops the machine. This collision protection therefore functions only if the touch probe has been activated.

The undamaged touch probe is recalibrated (via the control's calibration cycle), and you can continue working. The collision protection adapter does not cause any additional error—not even at high accelerations (e.g., during tool change).

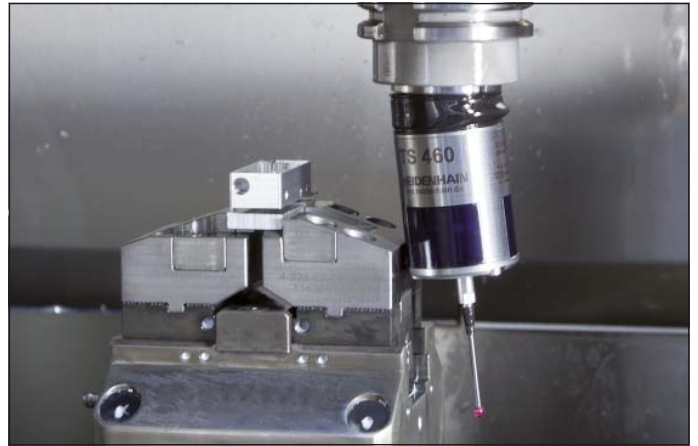

The collision protection adapter protects the touch probe from physical damage ...

Thermal decoupling

The collision protection adapter also functions as a thermal decoupler. This protects the touch probe from being heated by the spindle.

If the spindle heats up strongly as a result of previous machining operations, then the touch probe can also grow warm, particularly during measuring cycles of long duration. This can lead to faulty measurements. Thanks to its collision protection, the touch probe with thermal decoupling prevents heat from being conducted from the spindle to the touch probe.



... and serves as a thermal decoupler (at left, with collision protection adapter)

Styli

Styli for TS

HEIDENHAIN offers probe styli with various ball-tip diameters and stylus lengths. All styli are attached to the TS touch probes with an M3 thread. Starting from a ball-tip diameter of 4 mm, a rated breaking point protects the touch probe from mechanical damage caused by operator error. The following styli are included in delivery with the TS touch probes:

- For TS 150
T404
- For TS 260/TS 248
2 x T404
- For TS 460
T404 and T409
- For TS 444, TS 642 and TS 740
T404 and T424

When the coupling joint is used, the TS 260/TS 248 can be rotated into position in order to exactly align asymmetric or cuboid probe contacts.



Ball-tip styluses with steel shaft

| Model ID | Length l | Ball diameter D |
|----------|-----------|-----------------|
| T421 | 295770-21 | 21 mm |
| T422 | 295770-22 | 21 mm |
| T423 | 295770-23 | 21 mm |
| T424 | 352776-24 | 21 mm |
| T404 | 352776-04 | 40 mm |
| T405 | 352776-05 | 40 mm |
| T406 | 352776-06 | 40 mm |
| T408 | 352776-08 | 40 mm |
| T409 | 352776-09 | 60 mm |

Ball-tip styli with steel shaft

| Model ID | Length l | Ball diameter D |
|----------|-----------|-----------------|
| T510 | 805228-01 | 100 mm |
| T515 | 805228-02 | 150 mm |
| T520 | 805228-03 | 200 mm |
| T610 | 805228-07 | 100 mm |

Further styli, including special shapes, are available upon request.

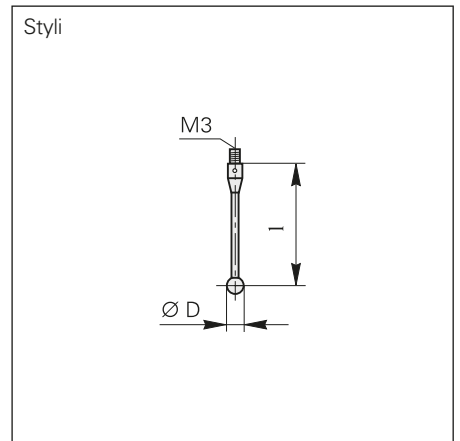

Star-type inserts

For up to five styli, e.g., T404 or T421
ID 1090725-01

Stylus adapters

For fastening styli with M4 thread
ID 730192-01

Stylus extension

| Model ID | Length l | Material |
|----------|-----------|----------|
| T490 | 296566-90 | 50 mm |
| | | Steel |

The stylus extension must be used only together with the short styli (21 mm length).

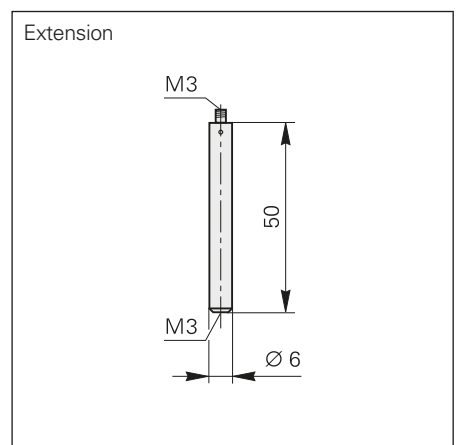

TS 248, TS 260, and TS 150

Workpiece touch probes

TS 248, TS 260



Axial flange socket



Radial flange socket

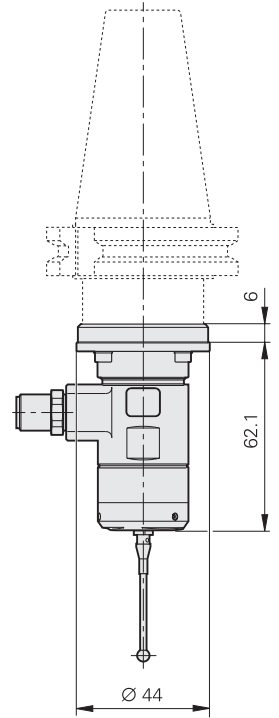
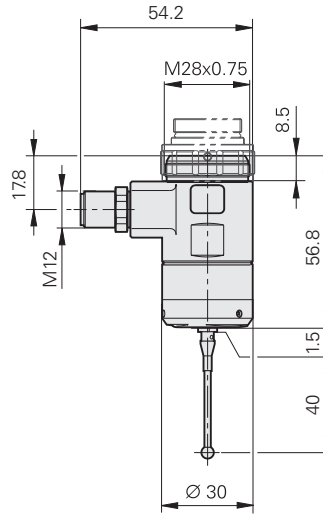
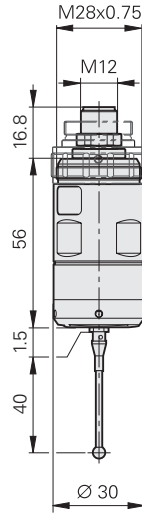

TS 150



With mounting base

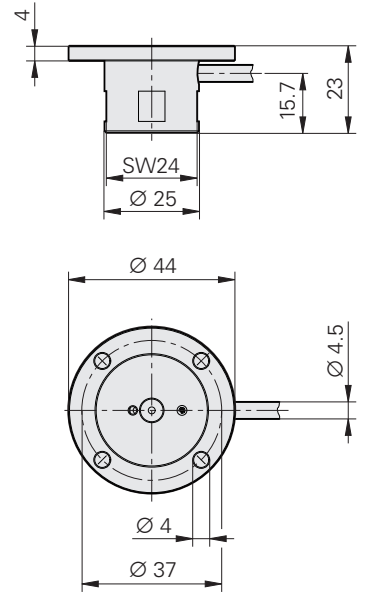
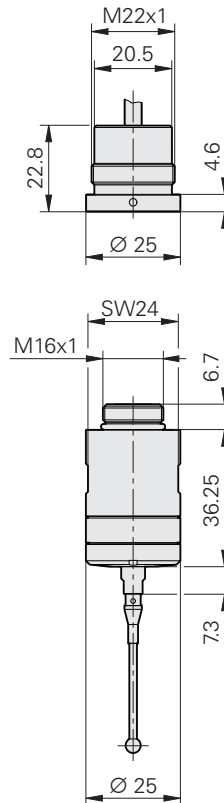

| Workpiece touch probe | Cable | |
|---|--|---|
| | TS 248 TS 260 | TS 150 |
| Probe accuracy | ≤ ±5 µm with use of the standard stylus T404 | |
| Probe repeatability Repeated probing from one direction | $2\sigma \leq 1\ \mu\text{m}$ at a probing velocity of 1 m/min <i>Typical values:</i> $2\sigma \leq 1\ \mu\text{m}$ at a probing velocity of 3 m/min $2\sigma \leq 4\ \mu\text{m}$ at a probing velocity of 5 m/min | |
| Deflection of probe contact | ≤ 5 mm in all directions (with stylus length L = 40 mm) | |
| Deflection force | <i>Axial:</i> approx. 8 N (TS 248: approx. 4 N) <i>Radial:</i> approx. 1 N (TS 248: approx. 0.5 N) | |
| Probing velocity | ≤ 5 m/min | |
| Protection EN 60529 | IP68 | |
| Operating temperature | 10 °C to 40 °C | |
| Storage temperature | -20 °C to 70 °C | |
| Mass without taper shank | ≈ 0.15 kg | ≈ 0.1 kg |
| Fastening* | <ul style="list-style-type: none"> • With taper shank¹⁾ (only with radial flange socket) • By M28x0.75 external thread • By coupling joint with M22x1 external thread | <ul style="list-style-type: none"> • By M16x1 external thread to the mounting base • Contact on the mounting base • Axial cable outlet: M22x1 for fastening to the machine • Radial cable outlet: Fastened to the machine with four M3 screws |
| Electrical connection* | M12 flange socket, 8-pin; axial or radial | Two-pole sliding contact on the mounting base |
| Cable length | ≤ 25 m | |
| Voltage supply | DC 15 V to 30 V/≤ 100 mA (without load) | Connected via UTI 150 |
| Output signal ²⁾ | <ul style="list-style-type: none"> • Trigger signals S and \bar{S} (square-wave signal and its inverted signal) • Floating trigger output | |
| HTL signal levels ²⁾ | $U_H \geq 20\ \text{V}$ at $-I_H \leq 20\ \text{mA}$ $U_L \leq 2.8\ \text{V}$ at $I_L \leq 20\ \text{mA}$ at DC 24 V rated voltage | |
| Signal transmission | Cable | |

* Please select when ordering

¹⁾ see *Mounting* page 18

²⁾ for TS 150 via UTI 150

TS 460, TS 642, and TS 740

Workpiece touch probes

mm



Tolerancing ISO 8015
ISO 2768 - m H
≤ 6 mm: ±0.2 mm



TS 460

With collision protection



TS 642



TS 740

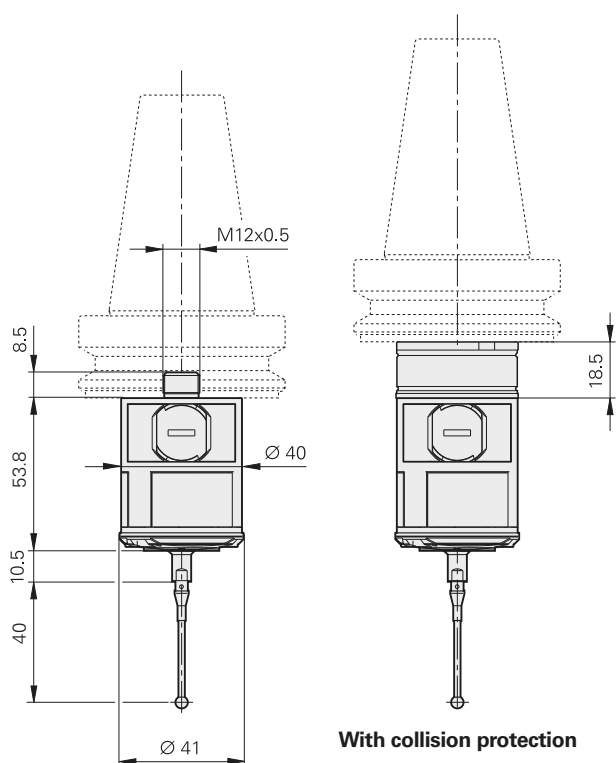

With collision protection

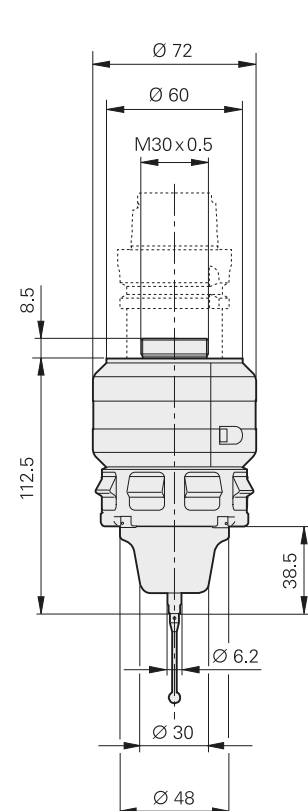
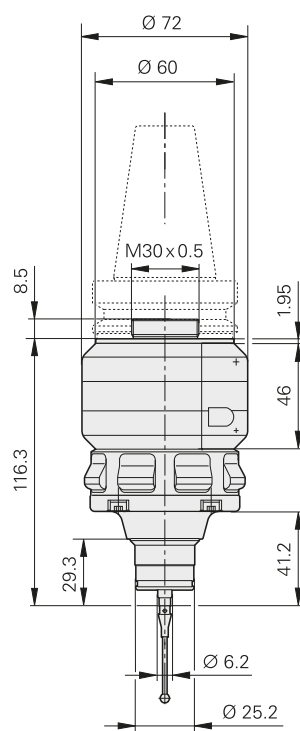

| Workpiece touch probe | Radio and infrared | Infrared | |
|---|---|--|--|
| | TS 460 | TS 642 | TS 740 |
| Probe accuracy | ≤ ±5 µm with use of the standard stylus T404 | | ≤ ±1 µm with use of the standard stylus T404 |
| Probe repeatability Repeated probing from one direction | $2\sigma \leq 1\ \mu\text{m}$ at a probing velocity of 1 m/min <i>Typical values:</i> $2\sigma \leq 1\ \mu\text{m}$ at a probing velocity of 3 m/min $2\sigma \leq 4\ \mu\text{m}$ at a probing velocity of 5 m/min | | $2\sigma \leq 0.25\ \mu\text{m}$ at a probing velocity of 0.25 m/min |
| Deflection of probe contact | ≤ 5 mm in all directions (with stylus length L = 40 mm) | | |
| Deflection force | <i>Axial:</i> Approx. 8 N <i>Radial:</i> Approx. 1 N | | <i>Axial:</i> Approx. 0.6 N <i>Radial:</i> Approx. 0.2 N |
| Probing velocity | ≤ 5 m/min | | ≤ 0.25 m/min |
| Collision protection | Optional | – | |
| Protection EN 60529 | IP68 | | |
| Operating temperature | 10 °C to 40 °C | | |
| Storage temperature | –20 °C to 70 °C | | |
| Mass without taper shank | ≈ 0.2 kg | Approx. 1.1 kg | |
| Fastening* | <ul style="list-style-type: none"> • With taper shank¹⁾ • By M12x0.5 external thread | <ul style="list-style-type: none"> • With taper shank¹⁾ • Without taper shank (connecting thread M30x0.5) | |
| Signal transmission | Radio and infrared transmission (selectable) with 360° range to SE | Infrared transmission with 360° range | |
| Transmission angle of infrared signal* | 0° or +30° | | |
| Interface* | HTL, EnDat 2.2 | HTL | |
| Transceiver unit* | <ul style="list-style-type: none"> • SE 661²⁾/SE 660 for radio and infrared transmission³⁾ • SE 642 for infrared transmission³⁾ • SE 540 for infrared transmission; for integration in the spindle head | SE 540, SE 642, or SE 660 (only infrared) | SE 540 or SE 642 |
| TS switch-on/off | Radio or infrared signal (selectable) from SE | Via switch in the taper shank or infrared signal from SE | Infrared signal from SE |
| Voltage supply | Two rechargeable or nonrechargeable batteries, 1 V to 4 V each, size $\frac{1}{2}$ AA or size LR2 | Two rechargeable or nonrechargeable batteries, 1 V to 4 V each, size C or size A ⁴⁾ | |
| Operating time | Typically 90 h ³⁾ with alkaline batteries (included in delivery); Typically 400 h ³⁾ possible with lithium batteries | Typically 400 h with alkaline batteries (included in delivery) Typically 800 h possible with lithium batteries | Typically 220 h with alkaline batteries (included in delivery) Typically 500 h possible with lithium batteries |

* Please select when ordering

¹⁾ see *Mounting* page 18

²⁾ With EnDat interface

³⁾ Reduced operating time if there is high surrounding radio traffic or if probing intervals are short and frequent

⁴⁾ Via adapter, included in delivery

SE 660, SE 642, and SE 540

Transceiver units



**SE 660
SE 661**

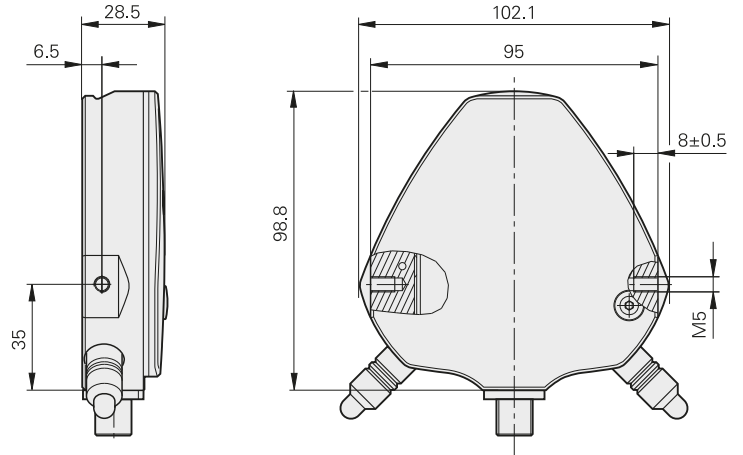

SE 642

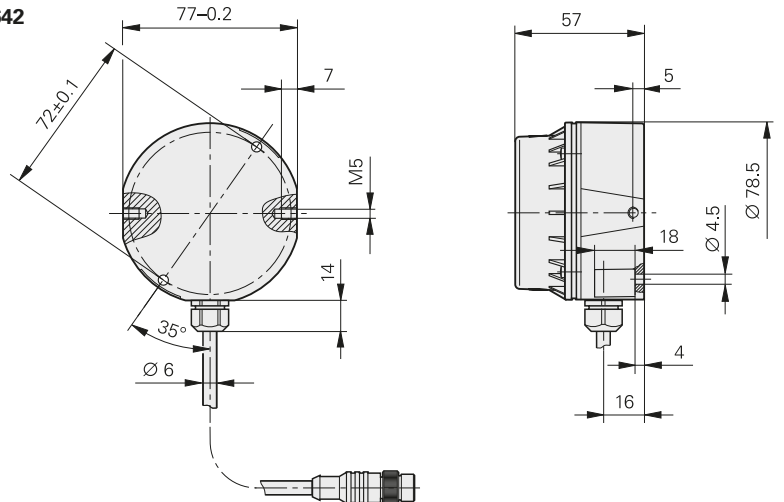

SE 540

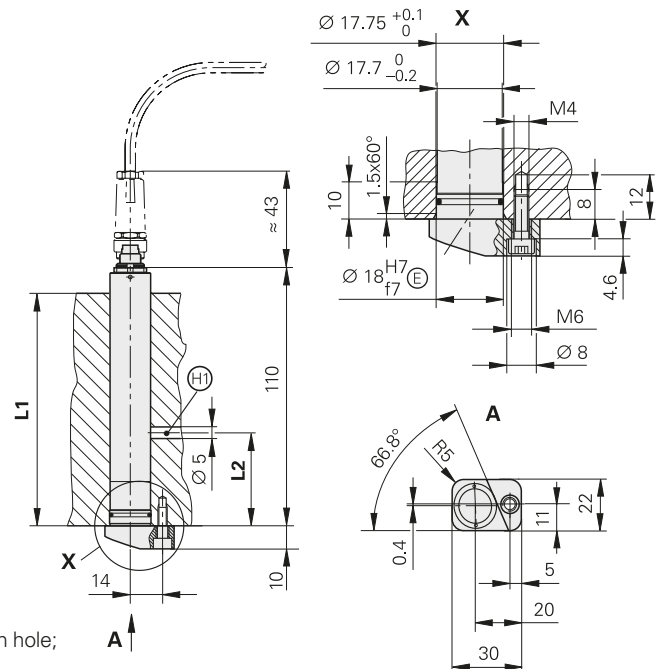

mm

 Tolerancing ISO 8015
 ISO 2768 - m H
 ≤ 6 mm: ±0.2 mm

⊕ = For L1 > 100: Provide a drain hole;
 L2 = 10 mm to 100 mm

| Transceiver unit | Radio and infrared | | Infrared |
|--|---|--|---|
| | SE 660 SE 661 | SE 642 | SE 540 |
| Use | TS 460 and TT 460 SE 660: Connects up to four each (depending on version) SE 661: Connects as many as desired | TS 460, TS 642, TS 740, and TT 460 | TS 460, TS 642, or TS 740 |
| Signal transmission | Radio or infrared | Infrared | |
| Area of application | In working space of machine | In working space of machine | In location hole in the spindle |
| Input/output signals | SE 660: Square-wave signals (HTL) <ul style="list-style-type: none"> • Start signals R(-TS) and R(-TT) • Ready signals R(-TS) and R(-TT) • Trigger signals S and \bar{S} • Battery warning \bar{W} SE 661: Serielle Signale (EnDat 2.2) <ul style="list-style-type: none"> • Activation • Trigger signal • Ready signal • Diagnosis | Square-wave signals (HTL) <ul style="list-style-type: none"> • Start signals R(-TS) and R(-TT) • Ready signals R(-TS) and R(-TT) • Trigger signals S and \bar{S} • Battery warning \bar{W} | Square-wave signals (HTL) <ul style="list-style-type: none"> • Start signal R • Ready signal B • Trigger signal \bar{S} • Battery warning \bar{W} |
| Optical status indicator | For infrared transmission, radio transmission, radio channel quality, channel, operating mode, and whether workpiece or tool touch probe | For infrared transmission, errors and whether workpiece or tool touch probe | For touch probe |
| Electrical connection | M12 flange socket SE 661: M12, 8-pin | Cable, 0.5 m/2 m, with M12 connector, 12-pin | M9 flange socket, 8-pin |
| Cable length | ≤ 20 m with Ø 6 mm adapter cable ≤ 50 m with Ø 6 mm adapter cable and Ø 8 mm adapter cable for extension SE 661: ≤ 50 m | | ≤ 30 m with adapter cable Ø 4.5 mm ≤ 50 m with Ø 4.5 mm adapter cable and Ø 8 mm adapter cable for extension |
| Voltage supply | DC 15 V to 30 V | | |
| Current consumption without load ¹⁾ | | | |
| Infrared | SE 660: 3.4 W _{eff} (≤ 200 mA _{eff}) SE 661: 3.8 W _{eff} (≤ 220 mA _{eff}) | 5.1 W _{eff} (≤ 250 mA _{eff}) | 3.7 W _{eff} (≤ 150 mA _{eff}) |
| Normal operation | SE 660: 10.7 W _{PK} (≤ 680 mA _{PK}) SE 661: 12 W _{PK} (≤ 755 mA _{PK}) | 8.3 W _{PK} (≤ 550 mA _{PK}) | 4.3 W _{PK} (≤ 210 mA _{PK}) |
| Transmission | SE 660: 2.1 W _{eff} (≤ 120 mA _{eff}) SE 661: 2.4 W _{eff} (≤ 135 mA _{eff}) | – | – |
| Radio | | | |
| Protection EN 60529 | IP68 | | |
| Operating temperature | 10 °C to 40 °C | 10 °C to 40 °C | U _P = 15 V: 10 °C to 60 °C U _P = 24 V: 10 °C to 40 °C |
| Storage temperature | –20 °C to 70 °C | –20 °C to 70 °C | –20 °C to 70 °C |
| Mass without cable | ≈ 0.3 kg | ≈ 0.2 kg | ≈ 0.1 kg |

* Please select when ordering
¹⁾ With minimum supply voltage

Selection guide

Tool measurement on the machine shortens non-productive times, increases machining accuracy, and reduces scrapping and reworking of machined parts. With the tactile TT touch probes and the contact-free TL laser systems, HEIDENHAIN offers two completely different possibilities for tool measurement.

With their rugged design and high degree of protection, these tool touch probes can be installed directly within the machine tool's work envelope.

TT touch probes

The TT 160 and TT 460 tool touch probes are touch trigger probes for the measurement and inspection of tools. The TT 160 features signal transmission by cable, while the TT 460 communicates wirelessly over a radio or infrared beam with the SE 660 transceiver unit.

The disk-shaped probe contact of the TT is deflected during physical probing of a tool. At that moment, the TT generates a trigger signal that is transmitted to the control, where it is processed further. The trigger signal is generated through a wear-free optical switch that ensures high reliability.

The probe contact is easy to exchange. The connection pin to the contact plate features a rated break point. This protects the touch probe from physical damage due to operator error.

TL laser systems

The TL Micro and TL Nano laser systems can measure tools at the rated speed without making contact. With the aid of the included measuring cycles, you can measure tool lengths and diameters, inspect the form of the individual teeth, and check for tool wear or breakage. The control automatically saves the measurement results in a tool table.

The measurement is fast and uncomplicated. Under program control, the NC control positions the tool and starts the measuring cycle. This is always possible before machining, between two machining steps, or after machining is finished.

The axially focused laser beam measures tools as small as 0.03 mm in diameter at a repeatability of up to $\pm 0.2 \mu\text{m}$.

| | TT touch probes | | TL laser system | | | |
|-------------------------------------|--|--|---|---------------------|-------------------------------|----------------------|
| | TT 160 | TT 460 | TL Nano | TL Micro 150 | TL Micro 200 | TL Micro 300 |
| Probing method | Physical probing | | Non-contacting by laser beam | | | |
| Probing directions | 3 dimensional: $\pm X$, $\pm Y$, $+Z$ | | 2 dimensional: $\pm X$ (or $\pm Y$), $+Z$ | | | |
| Probing forces | <i>Axial</i> : 8 N, <i>radial</i> : 1 N | | No forces, operates without contact | | | |
| Tool materials | Breakage-prone teeth are at risk | | Any | | | |
| Sensitivity to unclean tools | Very small | | High (tool must be cleaned with blown air before measurement) | | | |
| Possible measuring cycles | Length, radius, breakage, individual teeth | | Length, radius, breakage, individual teeth, tooth geometry (also for combined contours) | | | |
| Installation effort | Simple connection to NC control | | PLC adaptation in the NC control necessary (6 outputs, 3 inputs), compressed air connection | | | |
| Signal transmission | Cable | Radio/infrared to SE 660, SE 661; infrared to SE 642 | Cable | | | |
| Repeatability | $2 \sigma \leq 1 \mu\text{m}$ | | $2 \sigma \leq 0.2 \mu\text{m}$ | | $2 \sigma \leq 1 \mu\text{m}$ | |
| Min. tool diameter | 3 mm ¹⁾ | | 0.03 mm | | 0.1 mm | |
| Max. tool diameter | Unlimited | | 37 mm ²⁾ | 30 mm ²⁾ | 80 mm ²⁾ | 180 mm ²⁾ |

¹⁾ Probing force must not result in tool damage

²⁾ With centered measurement

Contents

| | | |
|--------------------------------------|------------------------------|----------------------------|
| TT touch probe | General information | 32 |
| | Principle of function | 33 |
| | Mounting | 34 |
| | Probing | 35 |
| | Specifications | TT 160, TT 460 36 |
| | TL laser system | General information |
| Components | | 39 |
| Mounting | | 40 |
| Protection from contamination | | 41 |
| Probing | | 42 |
| Specifications | | TL Nano 44 |
| | | TL Micro 46 |
| | DA 301 TL 48 | |



TT touch probes for tool measurement

Together with the measuring cycles of the CNC control, the TT tool touch probes enable the TNC to measure tools automatically while they are in the machine spindle. The control saves the values measured for tool length and radius in the central tool file. By inspecting the tool during machining, you can quickly and directly measure wear or breakage to prevent scrap or rework. If the measured deviations lie outside the tolerances, or if the monitored life of the tool is exceeded, the control can lock the tool or automatically insert a replacement tool.

With the **TT 460**, all signals are transmitted to the control via radio or infrared beam.

Benefits:

- Greatly increased mobility
- Fast installation at any location
- For use also on rotary and tilting axes

Your advantage: With the TT 160 or TT 460 tool touch probe, you can have your CNC machine operate unattended without losing accuracy or increasing scrap rates.



Principle of function

Sensor

Touch probes from HEIDENHAIN operate with an optical switch as sensor. A lens system collimates the light generated from an LED and focuses it onto a differential photocell. When the probe contact is deflected, the differential photocell produces a trigger signal. The probe contact of the TT is rigidly connected to a plate integrated in the probe housing on a three-point bearing. The three-point bearing ensures the physically ideal rest position.

With its contact-free optical switch, the sensor operates without wear, thereby ensuring the high long-term stability of HEIDENHAIN touch probes.

Repeatability

For workpiece measurement, the repeatability of the probing process is of primary importance. The probe repeatability specifies the error resulting from repeatedly probing a tool from one direction at an ambient temperature of 20 °C.

The probe accuracy of a touch probe is measured at HEIDENHAIN on precision measuring machines.

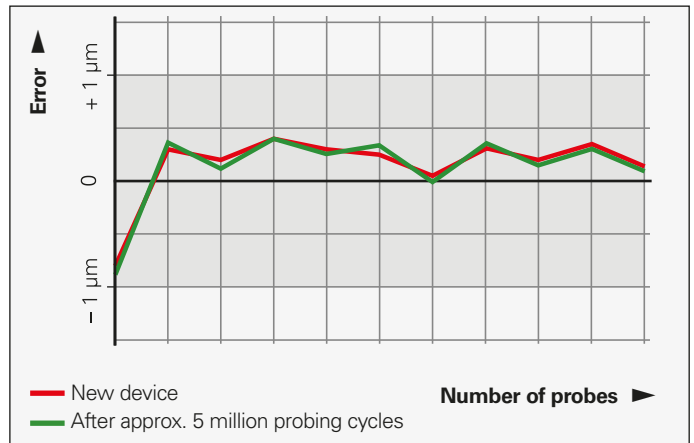
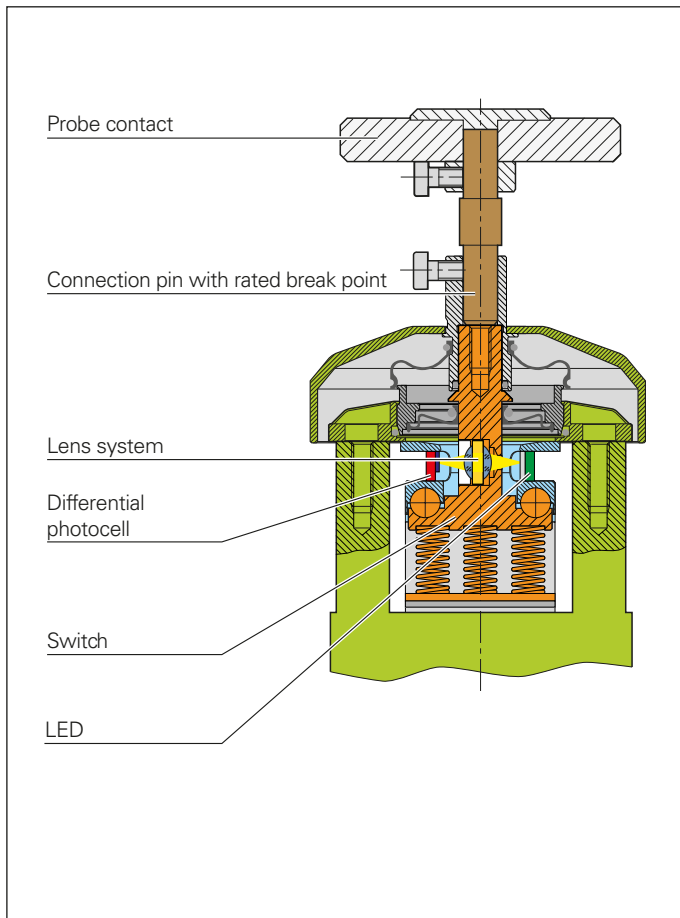

Typical repeatability curve of a touch probe: Results of repeated probing from one direction.

Mounting

The tool touch probes feature an IP67 rating and can therefore be installed within the working space of the machine. The TT is mounted with two fixing clamps or on a space-saving mounting base that is available as an accessory.

The TT with 40 mm probe contact should be operated vertically to ensure reliable probing and optimum protection against contamination. Like the cuboid probe contact, the 25 mm diameter SC02 probe contact can also be operated when mounted in a horizontal position.

During workpiece machining, the TT must be switched off to ensure that the vibrations that accompany normal machining do not trigger a probe signal and cause an interruption.

Accessories:

Mounting base for TT

For fastening with a central screw

TT 160, ID: 332400-01

TT 460, ID: 651586-01

Mounting base with blower/flusher jet

For cleaning the tool

Air connection for \varnothing 4/6 tube

ID 767594-01

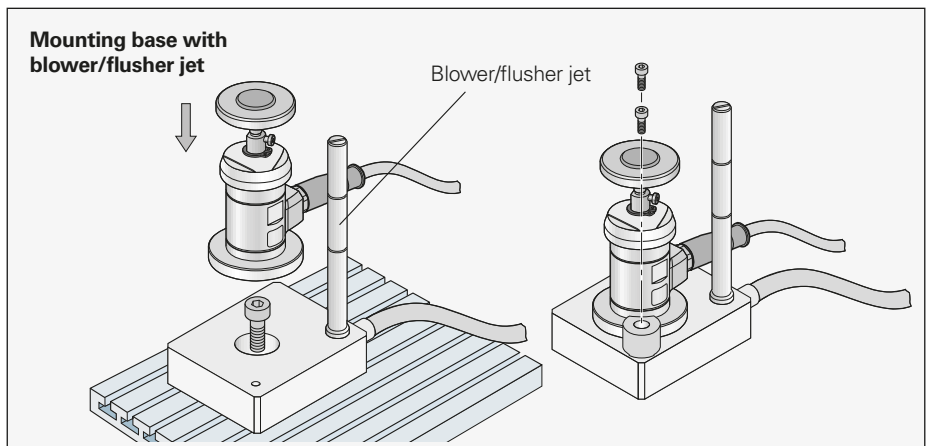
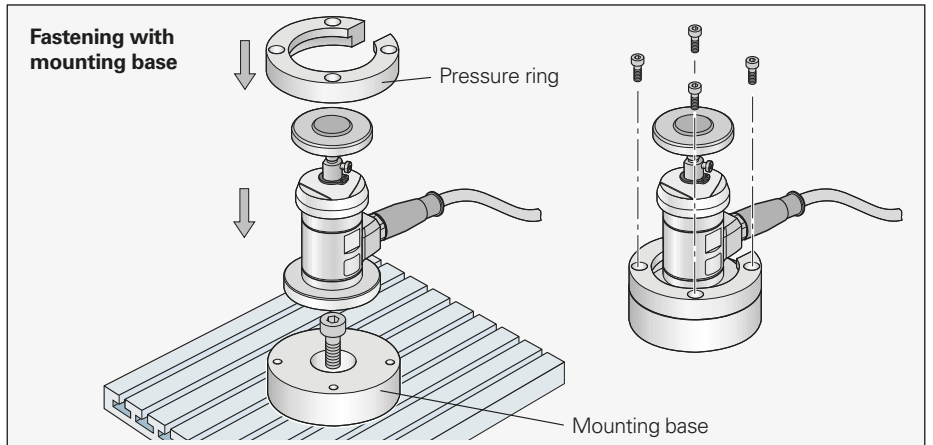
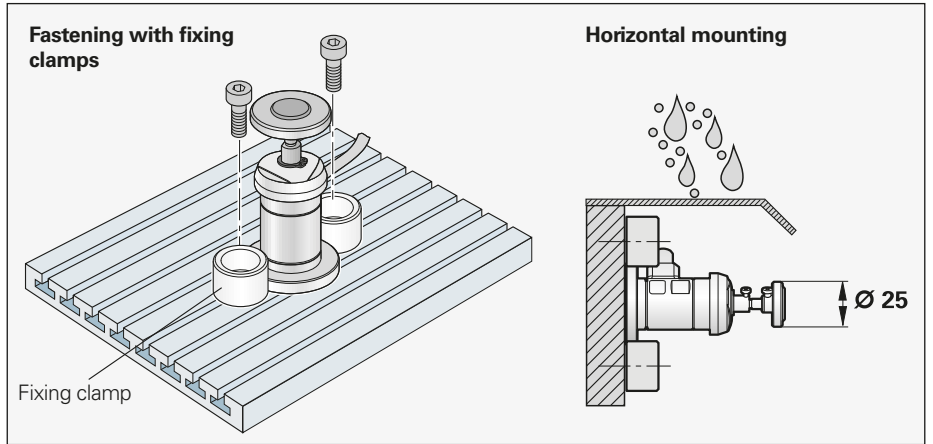

Power supply and signal transmission

For the TT 160 touch probe, both the power supply and the trigger signal are provided over the touch probe's cable.

The TT 460 transmits the trigger signal by infrared beam to the SE 660 transceiver unit (see page 14/15).

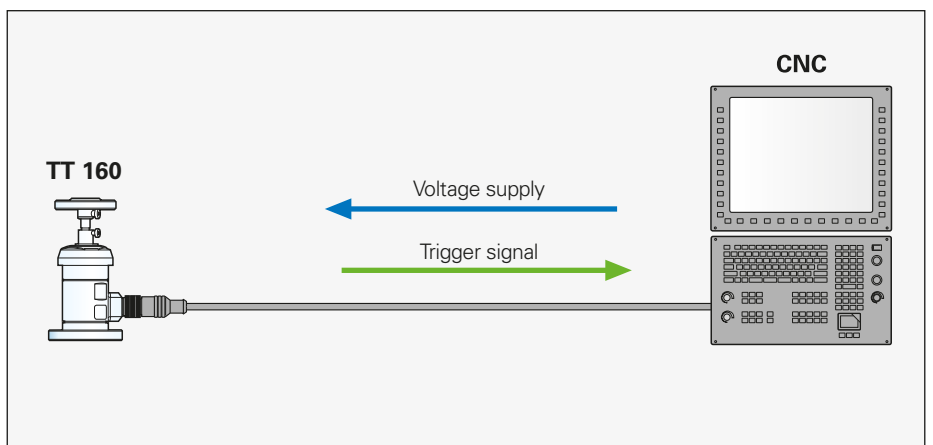

Probing

The hardened probe contact of the TT tool touch probe permits direct probing of the tool as it rotates opposite to the cutting direction. Speeds of up to 1000 rpm are permissible depending on the tool diameter. The probe contact is quickly exchanged: it is simply screwed into the touch probe through a fitting hole.

The maximum permissible deflection of the probe contact is 5 mm in any direction. The machine must stop moving within this distance.

The probe contact of the TT features a **rated break point** in order to protect the touch probe from physical damage due to operator error. The rated break point is effective in all probing directions. A rubber sleeve offers protection from splinters. A defective connection pin can easily be replaced without requiring readjustment of the TT.

Optical deflection display

LEDs on the TT 160 additionally indicate deflection of the probe contact. On the TT 460, the condition of the touch probe is shown by LEDs on the SE transceiver unit. This is especially useful for testing correct operation. You can see at a glance whether the TT is currently deflected.

Probe contacts

For probing **milling cutters**, the tool touch probes are equipped with a disk-shaped probe contact that is 40 mm in diameter (for example). A disk-shaped probe contact with a diameter of 25 mm is available as an accessory. Because of its small weight, it is particularly recommended for horizontal mounting of the TT.

The TT tool touch probe can also be used to calibrate **lathe tools**. The flat surfaces of a cuboid probe contact (available as an accessory) are contacted by the edges of the lathe tool. This makes it possible to regularly inspect tools in NC controlled lathes for breakage and wear in order to ensure process reliability.

The probe contacts can be ordered separately for replacement. They can easily be replaced without requiring readjustment of the TT.

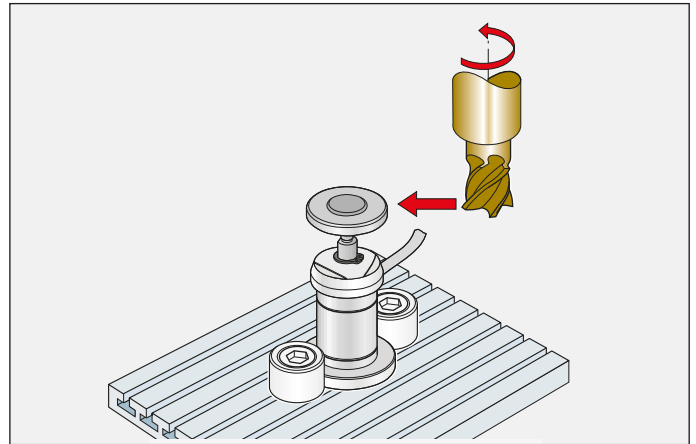

Connecting pin to the contact plate
(shown without rubber sleeve)

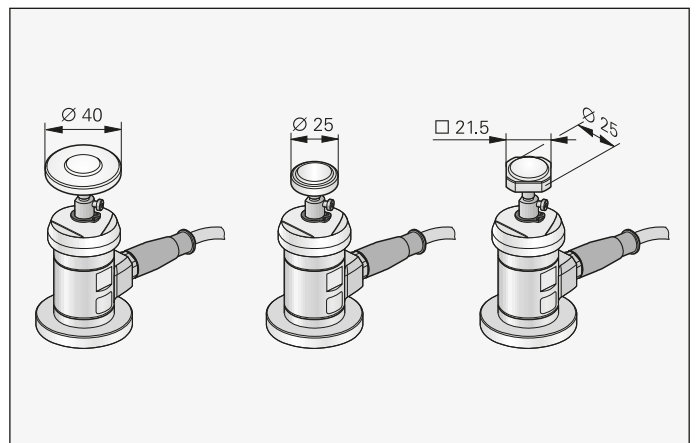

Accessories:

Probe contact SC02 Ø 25 mm
ID 574752-01

Probe contact SC01 Ø 40 mm
ID 527801-01

Probe contact cuboid
ID 676497-01

TT 160 and TT 460

Tool touch probes

TT 160

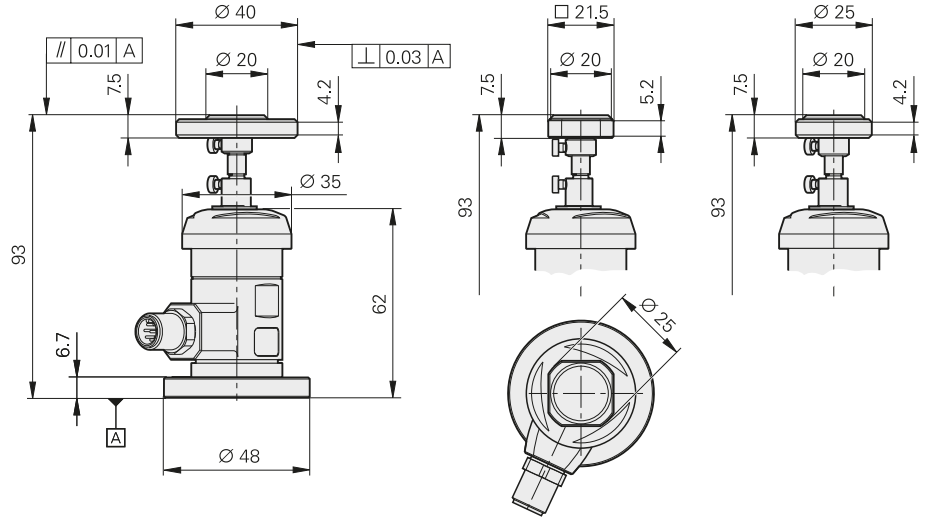

TT 460

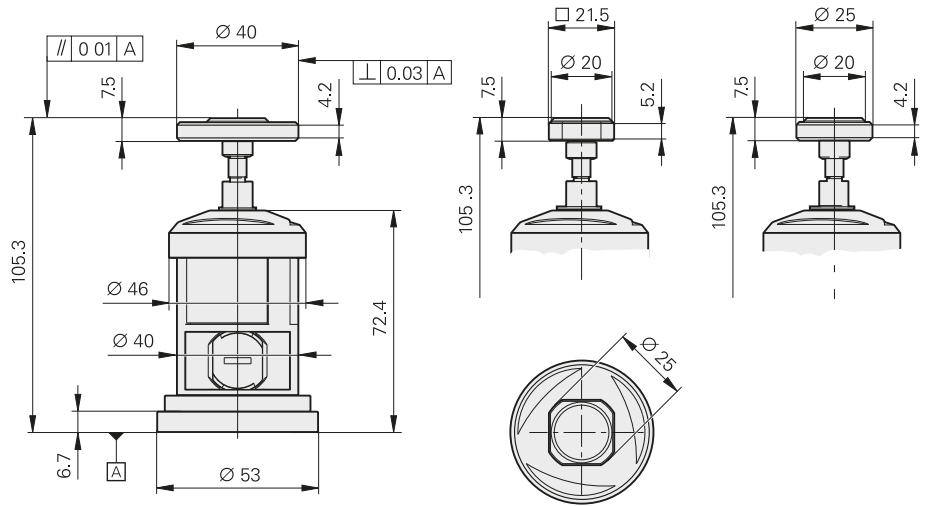

| Tool touch probe | Cable | Radio and infrared |
|---|--|---|
| | TT 160 | TT 460 |
| Probe accuracy | ≤ ±15 µm | |
| Probe repeatability Repeated probing from one direction | $2\sigma \leq 1\ \mu\text{m}$ at a probing velocity of 1 m/min <i>Typical values:</i> $2\sigma \leq 1\ \mu\text{m}$ at a probing velocity of 3 m/min $2\sigma \leq 4\ \mu\text{m}$ at a probing velocity of 5 m/min | |
| Deflection of probe contact | ≤ 5 mm in all directions | |
| Deflection force | <i>Axial:</i> approx. 8 N <i>Radial:</i> approx. 1 N | |
| Probing velocity | ≤ 5 m/min | |
| Protection EN 60529 | IP68 | |
| Operating temperature | 10 °C to 40 °C | |
| Storage temperature | -20 °C to 70 °C | |
| Mass | ≈ 0.3 kg | ≈ 0.4 kg |
| Mounting on the machine table | <ul style="list-style-type: none"> • Fastening by fixing clamps (included in delivery) • Fastening with mounting base (accessory) | |
| Electrical connection | M12 flange socket, 8-pin | – |
| Cable length | ≤ 25 m | – |
| Voltage supply | DC 10 V to 30 V/≤ 100 mA (without load) | 2 batteries (rechargeable or non-rechargeable) 1/2 AA or size LR2, each 1 V to 4 V |
| Operating time | – | Typically 90 h ³⁾ with alkaline batteries (included in delivery); Typically 400 h ³⁾ possible with lithium batteries |
| Interface* | HTL | HTL, EnDat 2.2 |
| Output signals | <ul style="list-style-type: none"> • Trigger signals S and \bar{S} (square-wave signal and its inverted signal) • Floating trigger output | – |
| HTL signal levels | $U_H \geq 20\ \text{V}$ at $-I_H \leq 20\ \text{mA}$ $U_L \leq 2.8\ \text{V}$ at $I_L \leq 20\ \text{mA}$ at DC 24 V rated voltage | – |
| Signal transmission | Cable | Radio or infrared transmission (selectable) with 360° range to SE |
| Transceiver unit | – | <ul style="list-style-type: none"> • SE 660²⁾ for radio and infrared transmission • SE 642²⁾ for infrared transmission • SE 661³⁾ for radio and infrared transmission |
| TT switch-on/off | – | Radio or infrared signal (selectable) from SE |

* Please select when ordering

¹⁾ Reduced operating time if there is much surrounding radio traffic, or short but frequent probing intervals

²⁾ SE shared by TS 460 and TT 460, see page 28

³⁾ With EnDat interface

⁴⁾ Reduced operating time if there is high surrounding radio traffic or if probing intervals are short and frequent

TL laser systems for tool measurement

Tool monitoring with a TL laser system represents a very versatile solution. The contact-free optical measurement enables you to check even the smallest tools rapidly, reliably, and without collision. Even the most sensitive tools are completely secure from damage.

The precise determination of the length and radius at the rated shaft speed ensures your high production quality. At the same time, this integrated tool setting with automatic updating of tool data eliminates the need for separate tool presetting and reduces both costs and non-productive times.

Tool monitoring occurs at the rated shaft speed in the real clamping system and thus under real operating conditions. Errors on the tool, spindle, and holder can be immediately detected and corrected. Every single tooth is measured at the highest speed. Even the geometry of special tools can automatically be checked on the machine for deviations.

The continual process inspection with monitoring of the tool data detects wear, tooth breakage and tool breakage before damage occurs. This ensures consistent production quality, avoids subsequent damage, and reduces the cost of scrapped or reworked parts. The measuring cycles operate automatically, ensuring optimum monitoring even during unattended operation.

The TL laser systems guarantee reliable tool monitoring, high measuring accuracy, and precise inspection for wear and tear. They offer the following benefits:

- Reduced non-productive times
- Unattended operation
- Less scrap
- Increased productivity
- Consistently high quality of production

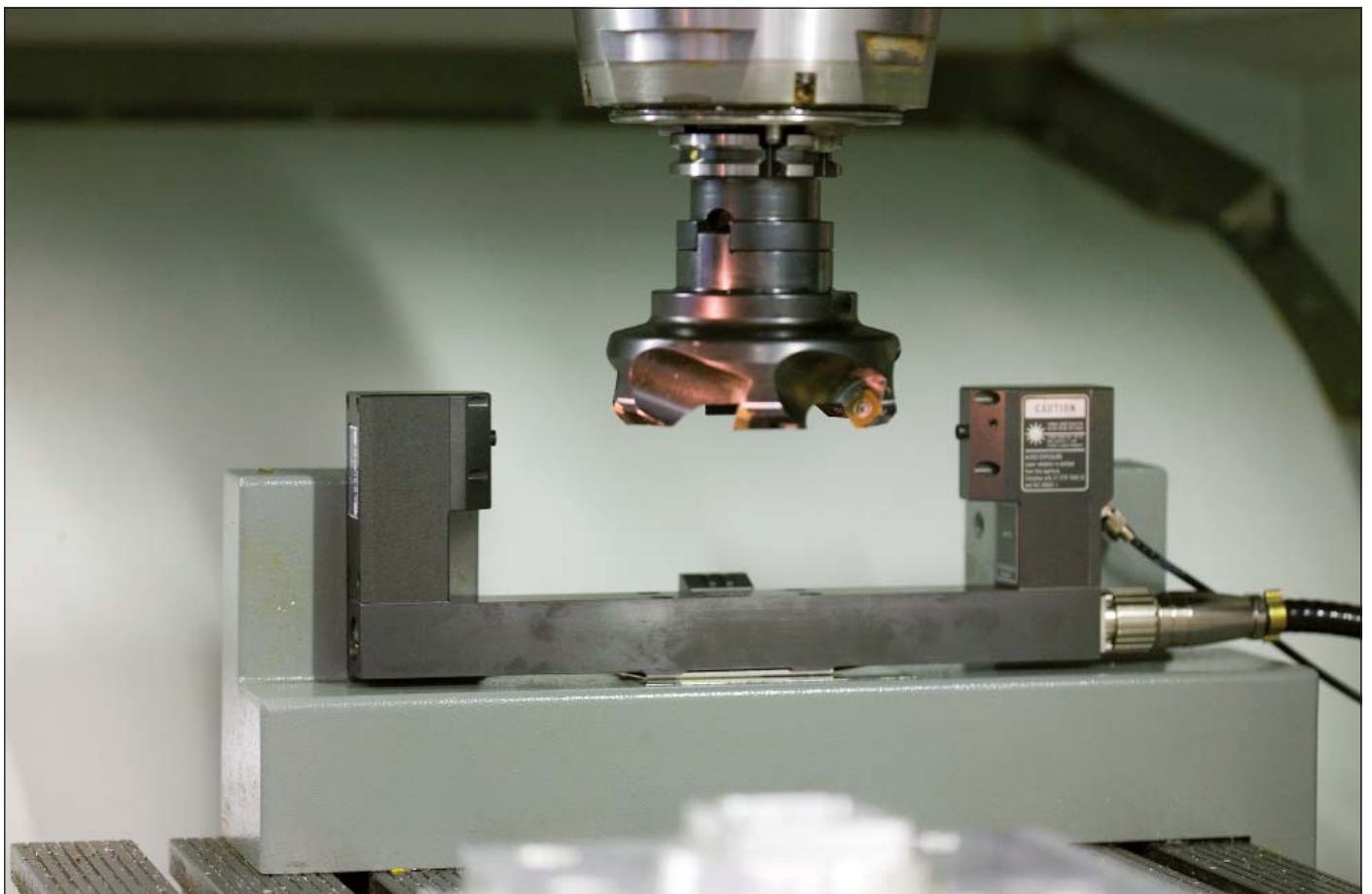

Components

TL laser systems

The laser systems are available in different versions for various maximum tool diameters:

- TL Nano
- TL Micro 150
- TL Micro 200
- TL Micro 300

The devices have an integral blowing unit to remove chips and coolant from the tool with a blast of compressed air.

The TL laser systems are optimized to the spindle shaft speed of NC machines for standard spindles and for HSC spindles (over 30 000 rpm).

The TL Micro systems are available as versions with cable exits and compressed air connections on the bottom or on the side.

Measuring cycles

The NC control uses measuring cycles to process the output signal of the laser systems and make the necessary calculations. Measuring cycles for the TNC 320, TNC 620, TNC 640, and iTNC 530 controls from HEIDENHAIN are included with the TL laser systems. The measuring cycles contain functions for:

- Tool setting with automatic transmission of the data to the tool table
- Inspection of wear and tear with or without correction of the tool data
- Identification with or without correction of the tool data

Compressed air unit

A **DA 301 TL** compressed air unit, specifically designed for these requirements, is necessary for operation of the TL laser systems. It consists of three filter stages (prefilter, fine filter, and activated carbon filter), an automatic condensation trap, and a pressure regulator with pressure gauge, as well as three control valves. They activate the sealing unit of the laser optics, supply the laser system with sealing air, and blow the tool clean. The PLC program triggers the control valves.

Accessories

The accessories simplify the mounting and maintenance of the TL laser systems.

TL Micro 300



TL Micro 200



TL Nano



Mounting

Mounting attitude

The TL laser systems fulfill the requirements for IP68 and can therefore be mounted directly within the machine's working space. For smooth operation, even in the presence of coolant and chips, the transmitter and receiver feature a pneumatically activated sealing system. The attachment of sealing air also provides a very high degree of protection against contamination.

The TL laser systems can be mounted in both upright and resting positions on or next to the machine table and must be stably mounted to guarantee high repeatability. The cutting edge should rotate in the appropriate direction for avoiding bothersome reflections and refractions during measurement by the laser beam.

The working space of the machine tool should be limited in order to prevent collision with the laser system during machining.

Aligning the TL

In order to achieve the best possible repeatability, the laser system must be mounted exactly parallel to two NC axes. For upright mounting on the machine table, the horizontal alignment is ensured by the mounting surface. The mounting tolerances are included in the dimension drawings. Deviations in the parallelism are particularly noticeable as linear errors when the lengths of very different tool diameters are measured. It is therefore recommended that the length of eccentric tools (e.g., end mills, face-milling cutters) be measured on the outside radius outside of the tool axis.

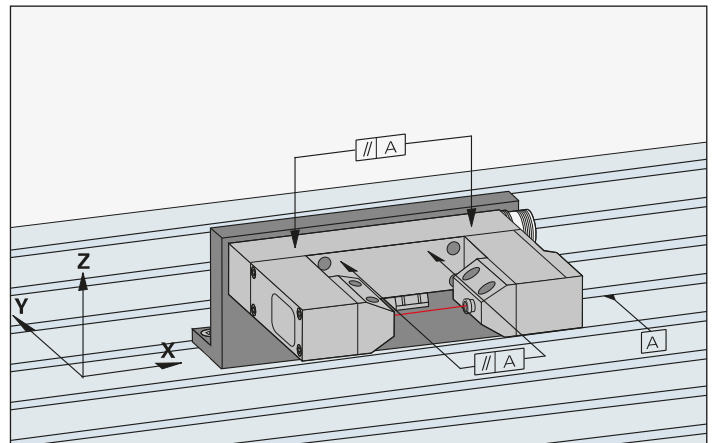
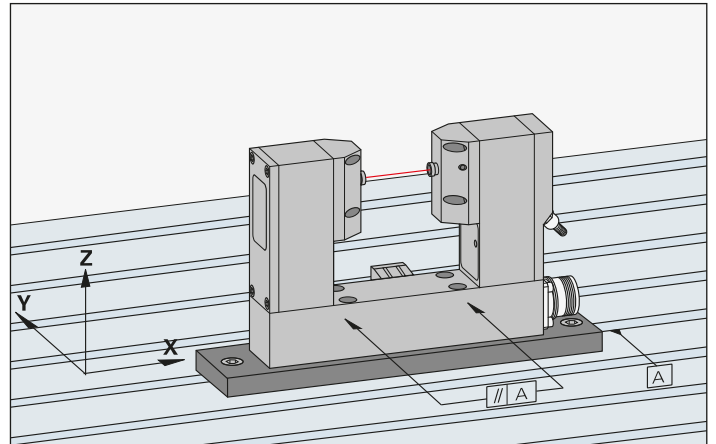

Mounting accessory for TL Micro

The mounting plate makes it very easy to install a TL Micro laser system on the machine table. Two stop pins on the base allow you to remove and reinstall the laser system without having to readjust it.

Accessories:
Mounting plate for TL Micro
ID 560028-01

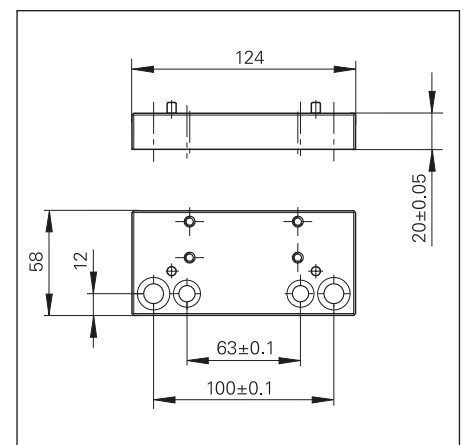

Protection from contamination

For the use of laser systems directly on machine tools, effective measures have been taken to protect the sensitive optical system of the laser light barrier.

Mechanical protection

The lenses of the laser systems are perfectly sealed against coolant and chips by contamination shutters with an integrated mechanical seal system. The seal enables the optical system only for the duration of the measurement. The shutter is actuated pneumatically by the DA 301 TL compressed air unit.

Sealing air

The transmitter and receiver of the laser light barrier are protected by very clean sealing air from the DA 301 TL compressed air unit. It prevents contamination of the optical system by coolant spray.

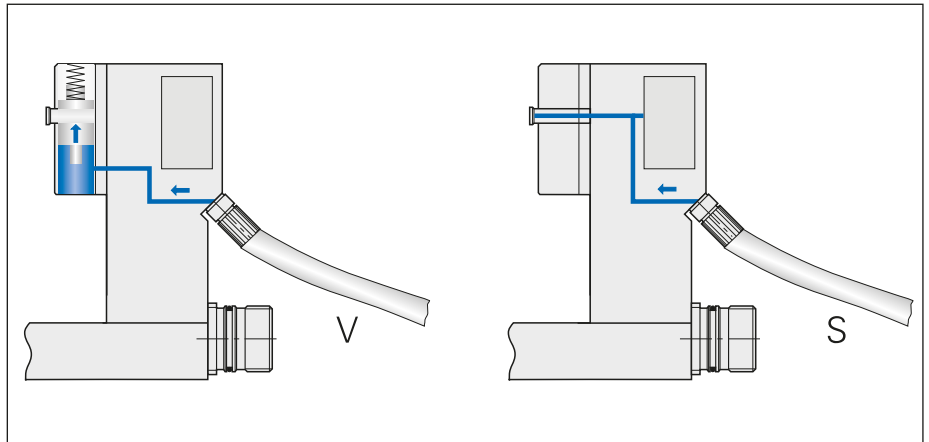

Pneumatic systems in the TL with connections for sealing air (S) and seal control (V)

Accessories

Maintenance kit for protective shutter

ID 560034-01

A maintenance kit consisting of the following items is offered for cleaning the contamination shutters of the laser optics.

- Gasket set
- Sintered sleeves
- Filler plugs
- O-rings
- M3x8 hexagon socket screws
- Special lubricant
- Operating Instructions

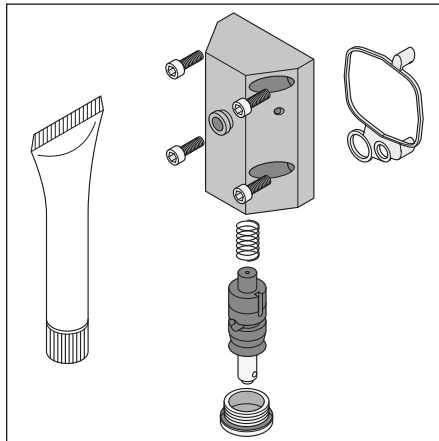

Replacement filters

ID 560036-01

Complete filter set for the DA 301 TL consisting of prefilter, fine filter, and activated carbon filter.

Protective springs

ID 560037-01

Set of spiral springs for protecting the compressed air tubing in the machine envelope

Set: 2 x Ø 6 mm, 1 x Ø 4 mm;
Length each: 1 m

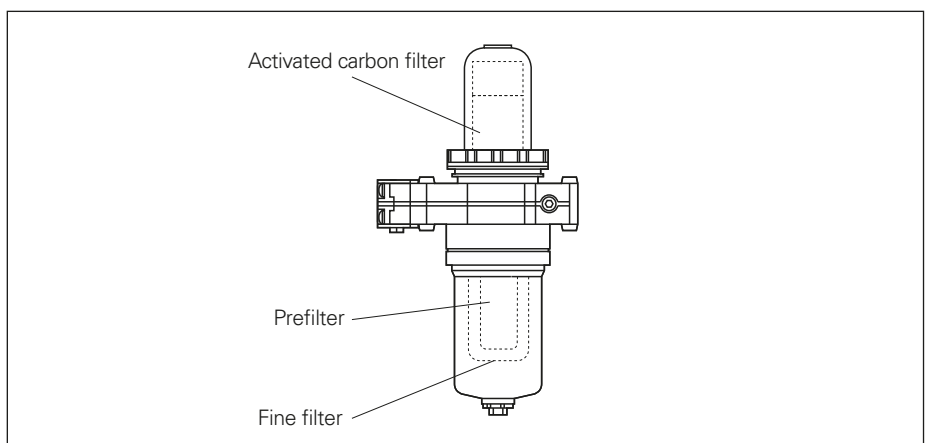

Probing

The TL laser systems operate as high-precision light barriers without any contact. A laser light source (protection class 2 as per IEC 825) emits a laser beam. The opposing receiver unit detects the laser beam and thereby captures every interruption. For any change in status—such as when a tool interrupts the laser beam or is removed again—the integral electronics generate a trigger pulse for a defined duration. This dynamic signal DYN is transmitted to the NC control, where it is used for capturing the position value. In addition, the laser system outputs the static signal STA for the duration that the laser beam is interrupted.

Calibrating

Before measurement with the TL laser system can be started, the system must be calibrated, meaning that the exact position of the trigger points relative to the machine coordinate system must be determined. A reference tool, available as an accessory, is used for this purpose. It has a characteristic shape for calibration, with a cylindrical dowel pin and a stepped inspection diameter for measurement in the positive and negative Z axis directions (for determining the exact position of the center of the laser beam in Z). The reference tool is clamped into the tool holder, and its length, diameter, and height are measured very exactly. A cylindrical dowel pin can suffice for simple applications. The lowest possible amount of radial runout must be ensured for the calibration measurement.

Accessory:
Reference tool
ID 560032-01

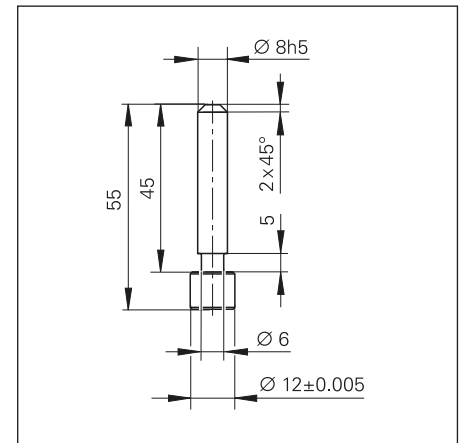
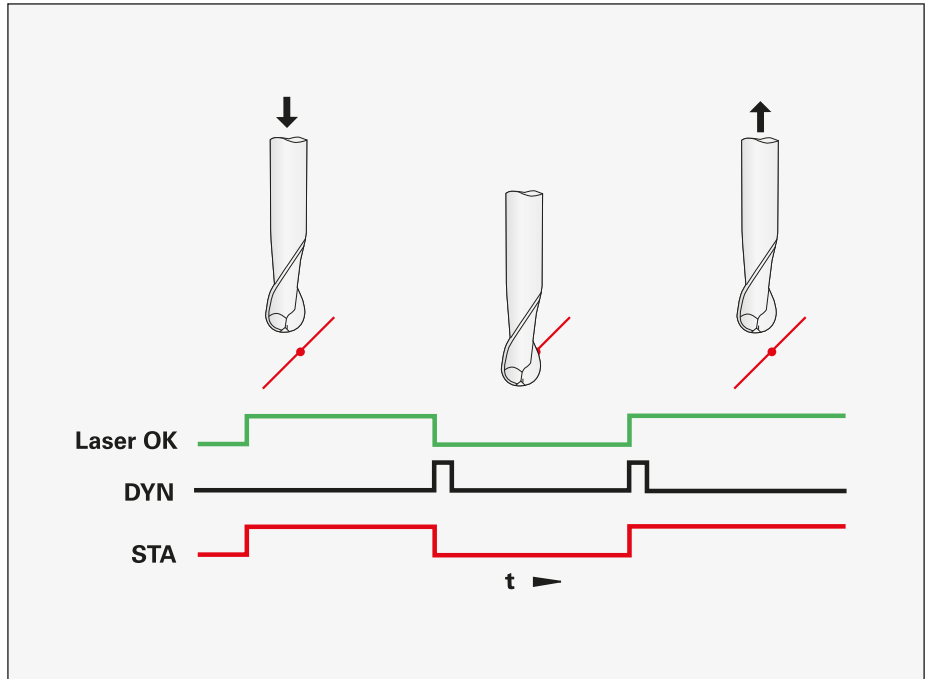

Probing strategies

The selection of the probing strategy also influences the reliability of the measurement. The measured value can be captured either when the tool is moved into the laser beam (“pushing measurement”) or when it is removed (“pulling measurement”). The pulling measurement ensures a high degree of protection against the influence of coolant and swarf, while the pushing measurement is the better method for engraving bits and tools with very small shaft diameters.

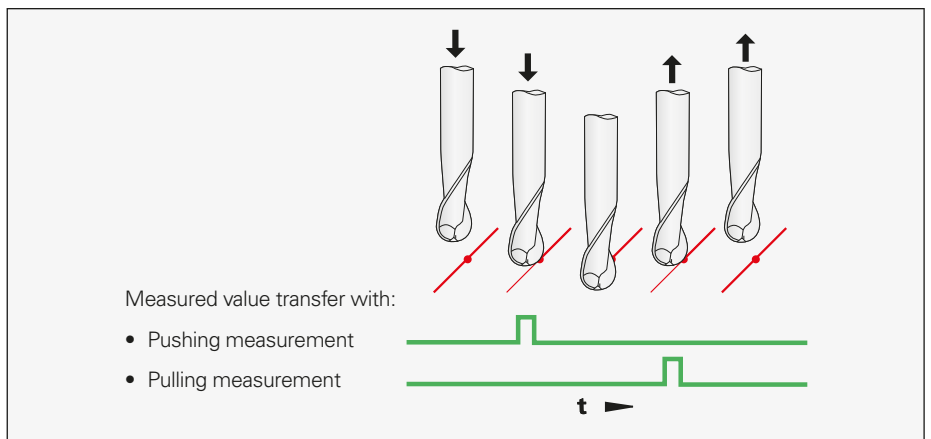





Operating modes

The operating mode of the laser system is defined through the ENABLE 1 and ENABLE 2 inputs. The measuring cycles automatically put the receiver in the appropriate operating mode.

During **inspection of individual teeth**, each available tooth generates an output pulse of defined duration. The pulse duration and the number of teeth define the basic speed. In the event of an error—a missing tooth or a tolerance error—the dynamic output signal (DYN) stays at LOW level for a maximum of 100 seconds.

In the **measuring** mode, every change of light causes a DYN output signal with a defined duration of 20 ms. The positive edge is evaluated. The device is switched between “pushing” and “pulling” measurement over the ENABLE 2 input.

| Mode of operation | ENABLE 1 | ENABLE 2 | Function |
|-------------------|----------|----------|---|
| 0 | 0 | 0 | Inspection of individual teeth Base speed 3750 rpm  |
| 1 | 0 | 1 | Pushing measurement Base speed ≥ 0 rpm  |
| 2 | 1 | 0 | <i>On version for standard machines*</i> Pulling measurement Base speed 600 to 3000 rpm  |
| | | | <i>On version for HSC machines*</i> Inspection of individual teeth Base speed 42000 rpm  |
| 3 | 1 | 1 | Pulling measurement Base speed ≥ 3000 rpm  |









* Please select when ordering

Optical status indicator

LEDs on the receiver side of the laser system make a rapid diagnosis of the status possible. In this way, the operator sees at a glance whether the laser beam path is OK, whether a dynamic trigger signal is being output, and which operating mode of the laser system is active.

Probing used tools

Of course, the optically scanning laser system cannot distinguish between the actual tool to be measured and any attached chips, coolant coating, or falling drops of coolant. In order to avoid faulty measurements, the tool should therefore be cleaned before measuring. This can be done by spinning off any particles at a high rotational velocity or by blowing them off with air. The TL laser systems feature an integral blowing feature for this, which can be used to clean the tool before and during a measuring cycle.

| Optical status indicator | LED | Function |
|--------------------------|---|-------------------------------------|
| Laser ON |  | Input for enabling transmission |
| Alignment |  | Laser adjustment OK (signal > 95 %) |
| Laser OK |  | Laser output OK (signal > 75 %) |
| Output |  | DYN output (signal > 50 %) |
| Mode |  | Operating mode 0 |
| |  | Operating mode 1 |
| |  | Operating mode 2 |
| |  | Operating mode 3 |

TL Nano

Laser system for tool measurement

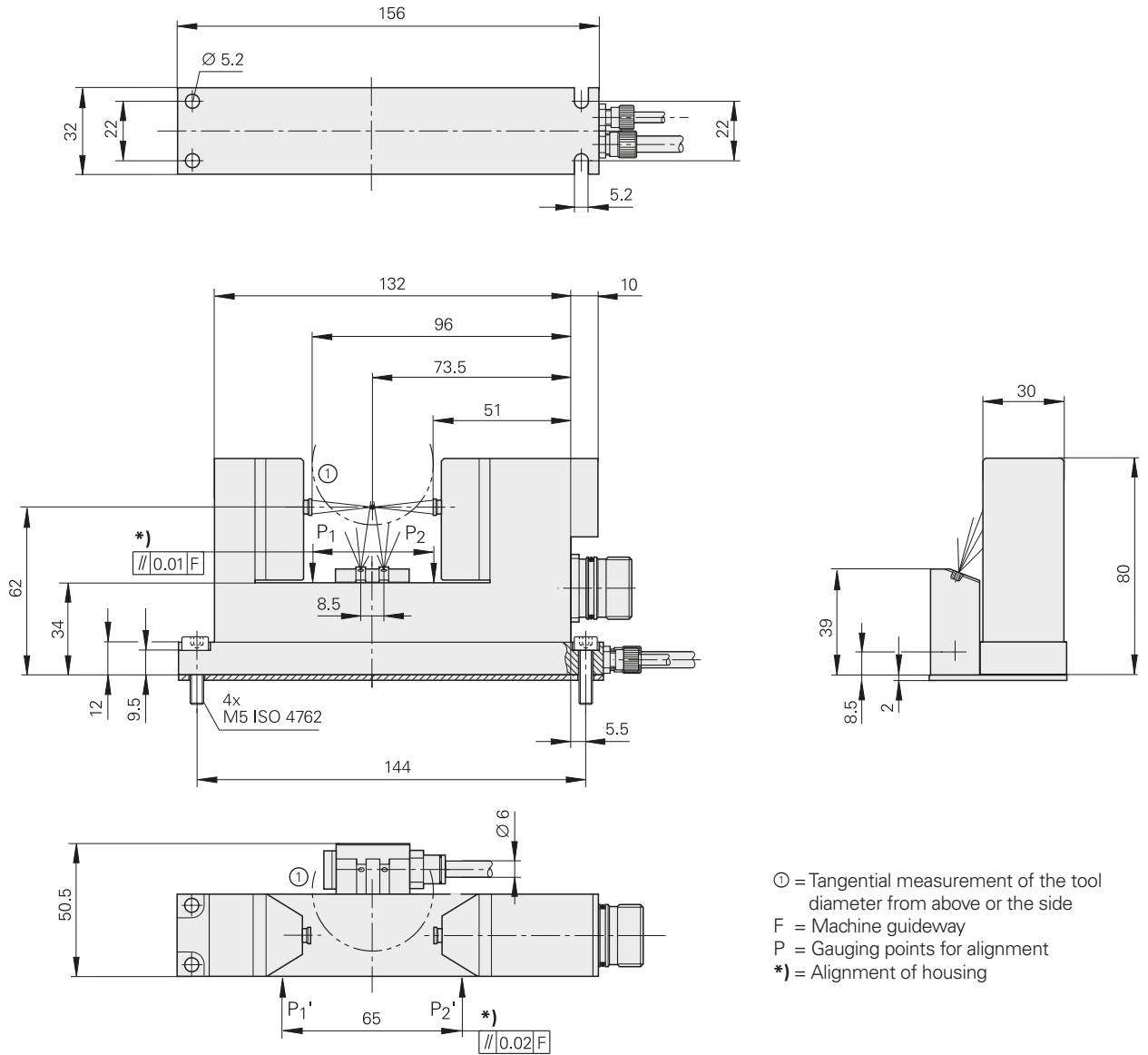

mm

 Tolerancing ISO 8015
 ISO 2768 - m H
 < 6 mm: ± 0.2 mm

| Specifications | TL Nano |
|---|---|
| Tool diameter Central measurement Tangential measurement | 0.03 mm to 37 mm 0.03 mm to 44 mm |
| Repeatability | ± 0.2 µm |
| Spindle speed* | For individual tooth measurement, optimized to standard spindles or HSC spindles (> 30 000 rpm) |
| Laser | Visible red-light laser with beam focused at center of system |
| Wavelength/Power | 630 nm to 700 nm/< 1 mW |
| Protection class IEC 825 | 2 |
| Input signals | Square-wave signals DC 24 V <ul style="list-style-type: none"> • Enable transmitter ENABLE 0 • Enable 1 to receiver ENABLE 1 • Enable 2 to receiver ENABLE 2 |
| Output signals | Square-wave signals DC 24 V <ul style="list-style-type: none"> • Dynamic triggering signal DYN • Static triggering signal STA • Proper laser function LASER OK |
| Voltage supply | DC 24 V/160 mA |
| Electrical connection | M23 flange socket (male), 12-pin, at side |
| Mounting | Within the machine work envelope |
| Protection EN 60529 | IP68 (when connected, with sealing air) |
| Tool cleaning | Blower |
| Operating temperature Storage temperature | 10 °C to 40 °C 0 °C to 50 °C |
| Mass | ≈ 0.70 kg (including blower) |

* Please select when ordering

TL Micro

Laser system for tool measurement

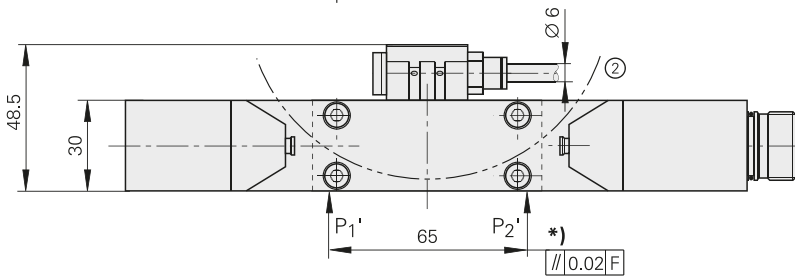
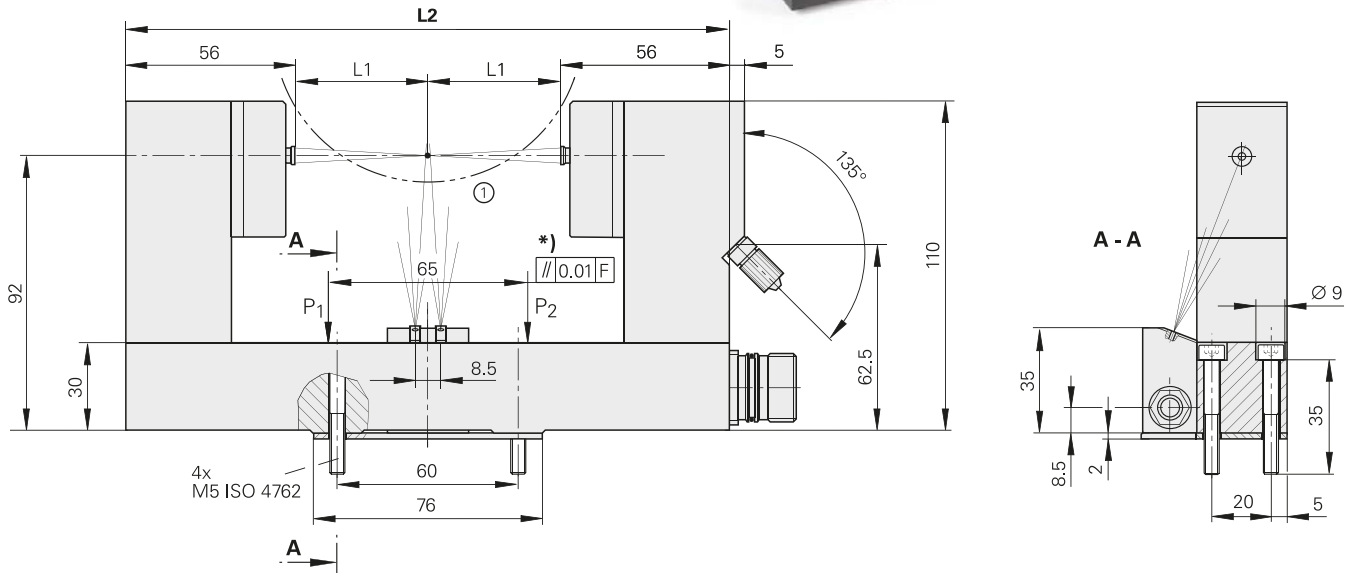

| L1 | L2 | Model |
|----|-----|--------------|
| 19 | 150 | TL Micro 150 |
| 44 | 200 | TL Micro 200 |
| 94 | 300 | TL Micro 300 |

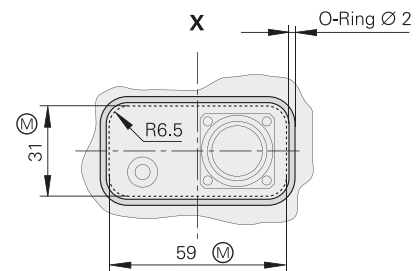
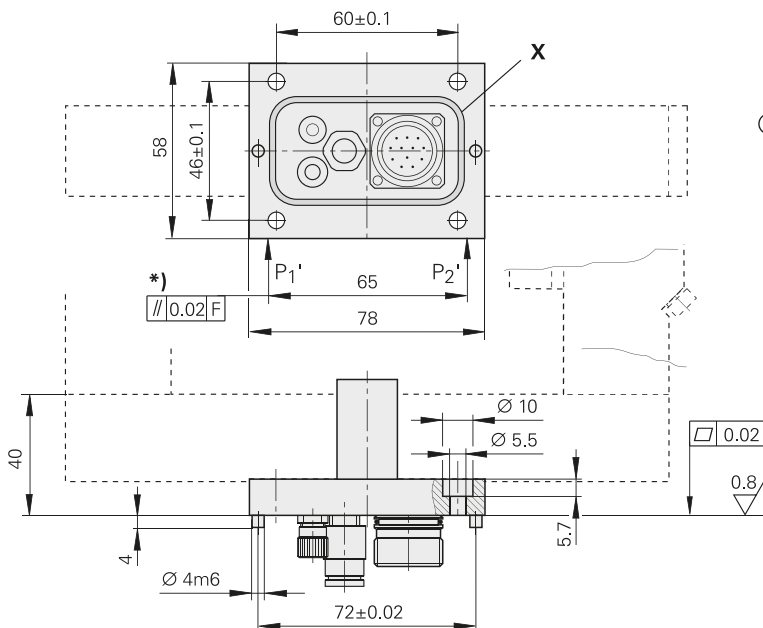

- ⊙ = Tangential measurement of the tool diameter from above
- ⊚ = Tangential measurement of the tool diameter from the side
- Ⓜ = Cutout for mounting
- F = Machine guideway
- P = Gauging points for alignment
- *) = Alignment of housing

mm

 Tolerancing ISO 8015
 ISO 2768 - m H
 < 6 mm: ±0.2 mm

| Specifications | TL Micro 150 | TL Micro 200 | TL Micro 300 |
|--------------------------------------|---|------------------|------------------|
| Tool diameter | | | |
| Central measurement | 0.03 mm to 30 mm | 0.1 mm to 80 mm | 0.1 mm to 180 mm |
| Tangential measurement from above | 0.03 mm to 30 mm | 0.1 mm to 98 mm | 0.1 mm to 324 mm |
| Tangential measurement from the side | 0.03 mm to 30 mm | 0.1 mm to 122 mm | 0.1 mm to 428 mm |
| Repeatability | ±0.2 µm | ±1 µm | |
| Spindle speed* | For individual tooth measurement, optimized to standard spindles or HSC spindles (> 30 000 rpm) | | |
| Laser | Visible red-light laser with beam focused at center of system | | |
| Wavelength/Power | 630 nm to 700 nm/< 1 mW | | |
| Protection class IEC 825 | 2 | | |
| Input signals | Square-wave signals DC 24 V <ul style="list-style-type: none"> • Enable transmitter ENABLE 0 • Enable 1 to receiver ENABLE 1 • Enable 2 to receiver ENABLE 2 | | |
| Output signals | Square-wave signals DC 24 V <ul style="list-style-type: none"> • Dynamic triggering signal DYN • Static triggering signal STA • Proper laser function LASER OK | | |
| Voltage supply | DC 24 V/160 mA | | |
| Electrical connection* | M23 flange socket (male), 12-pin, either on the side or bottom | | |
| Mounting | Within the machine work envelope | | |
| Protection EN 60529 | IP68 (when connected, with sealing air) | | |
| Tool cleaning | Blower | | |
| Operating temperature | 10 °C to 40 °C | | |
| Storage temperature | 0 °C to 50 °C | | |
| Mass | Including blower | | |
| Cable outlet lateral | ≈ 0.85 kg | ≈ 0.95 kg | ≈ 1.15 kg |
| Cable outlet downward | ≈ 0.90 kg | ≈ 1.00 kg | ≈ 1.20 kg |

* Please select when ordering

DA 301 TL

Compressed air unit for TL laser system

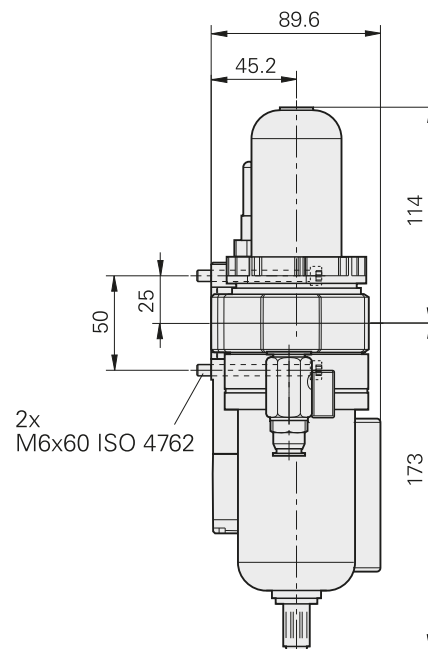
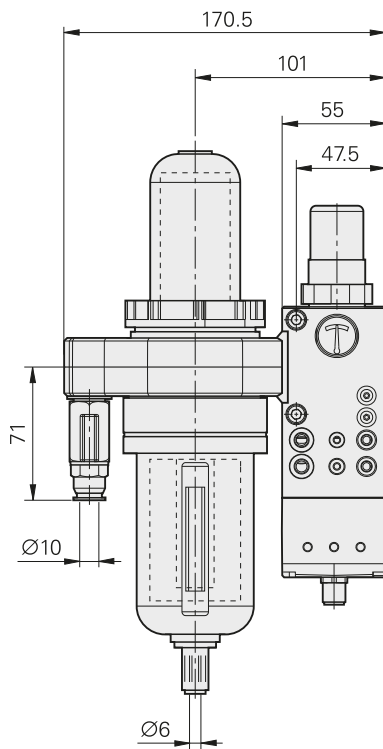

mm

Tolerancing ISO 8015
ISO 2768 - m H
< 6 mm: ±0.2 mm

| Specifications | DA 301 TL |
|--|--|
| Configuration | |
| Filter system | <ul style="list-style-type: none"> • Prefilter for particle sizes down to 5 µm • Fine filter for particle sizes down to 0.01 µm • Activated carbon filter for particle sizes down to 0.001 µm |
| Pressure regulator with pressure gauge | For setting the output pressure |
| Control valves | Release compressed air for <ul style="list-style-type: none"> • Sealing air • Workpiece blower • Sealing unit of the laser optics |
| Overpressure for operation | 4 bars to 6 bars |
| Air quality | |
| Air in | DIN ISO 8573-1 Class 4.3.4 |
| Air out | DIN ISO 8573-1 Class 1.3.1 |
| Flow rate | ≥ 400 l/min (without flushing/blowing feature) |
| Connections | |
| Compressed air inlet | G 3/8" |
| Compressed air outlet | Quick disconnects for <ul style="list-style-type: none"> • Sealing air: ∅ 6 mm • Flusher/blower: ∅ 6 mm • Sealing unit: ∅ 4 mm |
| Mass | ≈ 4.4 kg (without cable) |
| Items supplied | DA 301 TL compressed air unit 1 x 13 m pressure tubing ∅ 4 mm 2 x 13 m pressure tubing ∅ 6 mm 3 x 10 m cable for triggering the control valves |

Voltage supply

Cable-connected touch probes

The cable-connected TS 260, TS 248, and TT 160 touch probes; the SE transceiver unit; and the TL laser systems are powered by the control. The cable-connected TS 150 touch probe receives its voltage supply from the UTI 150. The maximum cable lengths shown in the specifications apply for HEIDENHAIN cables.

Wireless touch probes

The **TS 460**, **TS 642**, **TS 740** and **TT 460** wireless touch probes receive their voltage supply from two rechargeable or non-rechargeable batteries with a nominal voltage of 1 V to 4 V. The operating time depends heavily on the type and size of battery used (see table for examples). The typical service life data shown in the specifications apply only to the lithium batteries included in delivery. An operating time of 400 h assumes use over 12 months in triple-shift operation and at a 5 % usage rate.

The touch probe electronics automatically detect the type of batteries used. If the battery capacity falls below 10 %, the SE transmits a warning to the control. For operation with rechargeable batteries, the touch probes are provided with deep discharge protection: the probe switches off before the battery charge is exhausted.

The TS 460 and TT 460 touch probes feature intelligent battery management in order to minimize current consumption. The touch probe switches in steps to the stand-by condition: the longer a touch probe has been switched off, the less current it consumes. Activating a touch probe from a low standby level takes only a split second longer. This ensures high, application-oriented availability.

When switched off, the TS 642 and TS 740 touch probes go into stand-by mode and, after eight hours, into the sleep mode. You must then take a longer startup time into account when reactivating the touch probe (see *Switching the TS 642/TS 740 on/off*).

| | Battery size | Operating time ¹⁾ | | |
|--------------------------------|----------------------|------------------------------|-------------------------|--------------|
| | | Lithium battery | Alkaline battery | NiMH battery |
| TS 460 TT 460 | 1/2 AA N/LR1/Lady | 400 h – | – 90 h ³⁾ | 60 h 60 h |
| TS 642 | C | 800 h | 400 h | 250 h |
| | A ²⁾ | 400 h | 200 h | 125 h |
| TS 740 | C | 500 h | 220 h ³⁾ | 140 h |
| | A ²⁾ | 250 h | 110 h | 70 h |

1) **Note:** These are approximate values that can vary by manufacturer.

2) Via adapter

3) Included in delivery

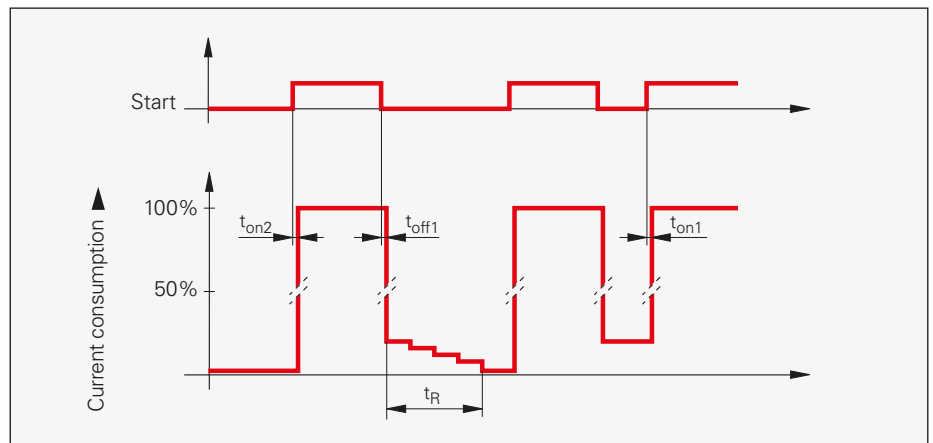

TS 460/TT 460 current consumption

Signal times

Switch-on delay

- From stand-by mode: t_{on1} typically 1 s
- From reduced consumption mode: t_{on2} typically 0.25 s

Switch-off delay

- With infrared transmission: $t_{off1} < 1$ s
- With radio transmission: $t_{off1} < 1$ s

Interfaces

TS and TT touch probes

Please refer to the **General electrical information in the Interfaces of HEIDENHAIN Encoders brochure.**

Touch probes with signal transmission by cable

When the stylus or the probe contact of the **TS 150, TS 260, TS 248** and **TT 160** is deflected, it triggers a square-wave signal **S** and its inverted signal **\bar{S}** .

HTL signal levels S, \bar{S}

$U_H \geq (U_P - 2.2 \text{ V})$ at $-I_H \leq 20 \text{ mA}$

$U_L \leq 1.8 \text{ V}$ at $I_L \leq 20 \text{ mA}$

In addition, the TS 260, TS 248, and TT 160 touch probes feature two floating switch outputs (**Trigger NO** and **Trigger NC**), which serve as normally closed contact and normally open contact via optocoupler.

Load capacity of optocoupler

$U_{\text{max}} \leq 15 \text{ V}$

$I_{\text{max}} \leq 50 \text{ mA}$

$\Delta U \leq 1 \text{ V}$ (typically 0.3 V at $I = 50 \text{ mA}$)

Since the spindle must be locked in position before the TS can be inserted, the connecting and adapter cables are equipped with jumpers. This enables the CNC to conduct the required safety check when the touch probe is connected.

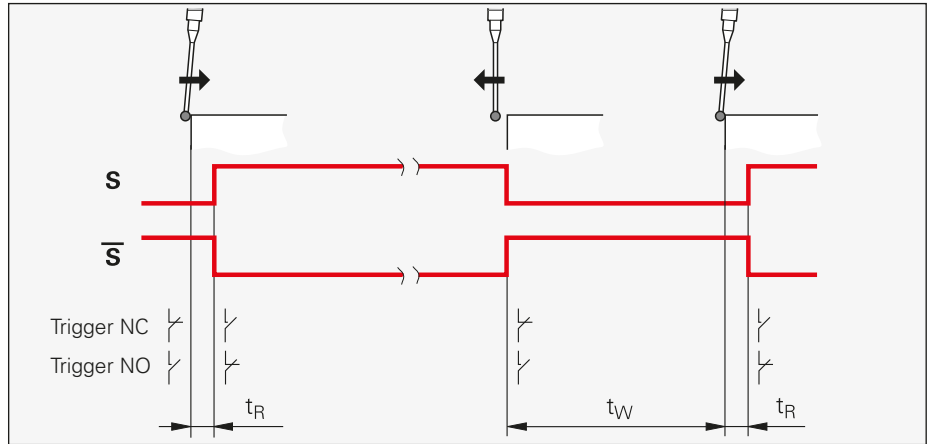

Trigger signal for TS 260/TS 248/TT 160

Response time $t_R \leq 10 \mu\text{s}$

Repeat interval $t_W > 25 \text{ ms}$

Touch probes with wireless signal transmission

The **TS 460, TS 740** and **TT 460** touch probes are switched on by the CNC over the SE. The rising edge of the **start signal R** activates the TS, and the falling edge deactivates it.

The **TS 642** touch probe is activated by inserting it in the spindle by the microswitch integrated in the taper shank.

The SE uses the **ready signal B** to report to the control that the touch probe is activated and within the reception area of the SE. The workpiece can now be probed.

The delay t when switching the probe on or off depends on the distance between the SE and TS, as well as the mode of the touch probe's power supply. Subsequent to initial activation (when the TS is in standby mode), the typical value for activation is 250 ms; for deactivation, it is 350 ms (1000 ms for the max. distance). When activating the probe after a longer interval (more than 8 hours—the TS is in the sleep mode), the delay can be up to 3 s. If the touch probe does not respond, the SE aborts the switch-on/off attempt after 3.5 s.

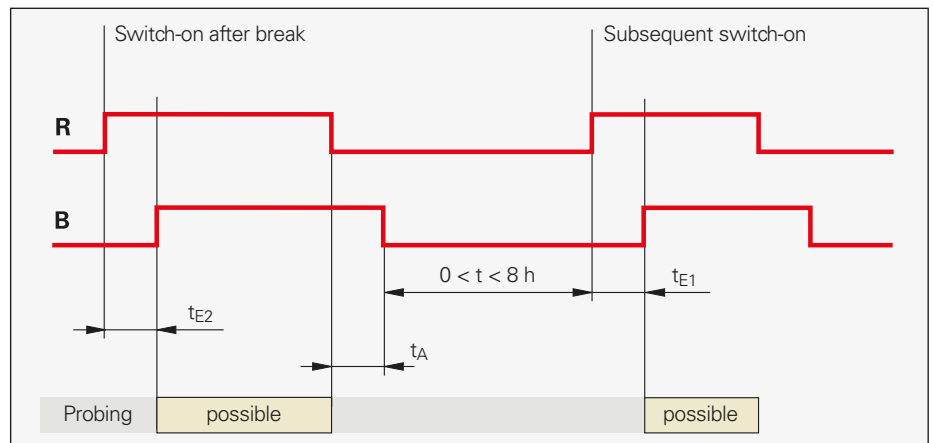

Switching the TS 460/TS 740/TT 460 on and off

Signal times

Switch-on Delay

$t_{E1} \leq 1000 \text{ ms}$ (typically 250 ms)

$t_{E2} \leq 3000 \text{ ms}$

Switch-off delay

$t_A \leq 1000 \text{ ms}$ (typically 350 ms)

Certain versions of the **TS 460** and **TT 460** touch probes are available with the **EnDat interface**. The EnDat interface from HEIDENHAIN is a digital, bidirectional interface that transmits trigger signals as well as diagnostic information and additional touch probe data. Multiple items of data can be transmitted simultaneously thanks to the serial transmission method.

The EnDat interface transmits the following data:

- Installation
 - Device name
 - ID number
 - Serial number
 - Type of transmission (infrared or radio)
 - Radio channels
 - Connect touch probe with SE

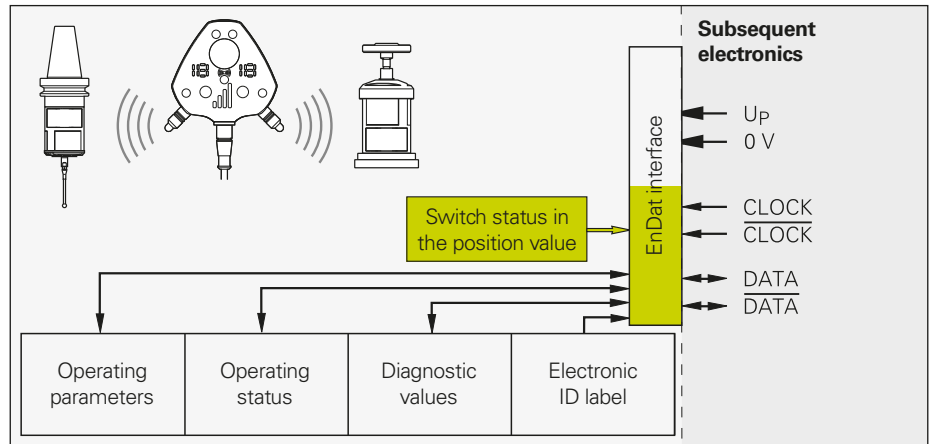

- Probing
 - Timestamp
 - Probing position (independent of the probing velocity)
 - Touch probe is ready
 - Stylus deflected
- Diagnostics
 - Battery level (bar display)
 - Collision
 - Signal strength

When the stylus is deflected, it releases the square-wave **trigger signal \bar{S}** .

Signal times

Response time t_{R1}

- With infrared transmission: 0.2 ms
 - With radio transmission: 10 ms
- Repeat interval $t_W > 25$ ms

In the event of a disturbance, the ready signal B is reset. The response time between occurrence of the disturbance and the resetting of the ready signal depends on the type of signal transmission.

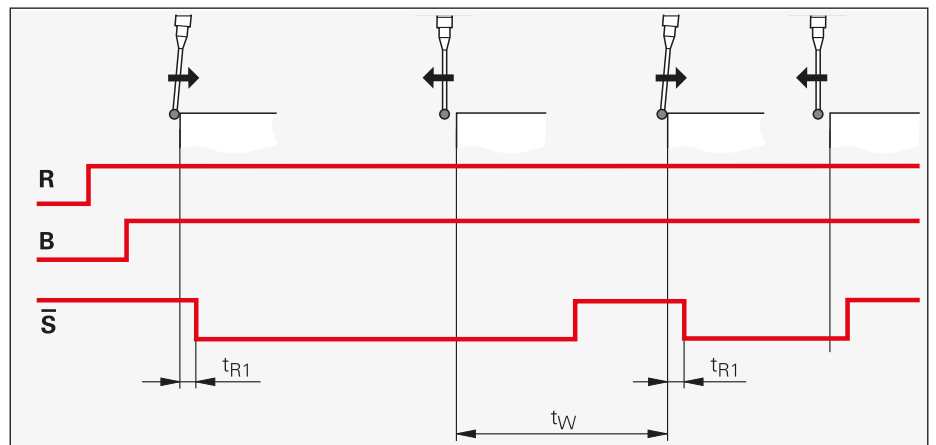

Probing with TS 460/TS 642/TS 740/TT 460

Signal times

Response time for interrupted signal transmission t_s

- With infrared transmission: ≤ 40 ms
- With radio transmission: ≤ 55 ms

Response time for collision (with collision protection adapter) t_s

- With infrared transmission: ≤ 40 ms
- With radio transmission: ≤ 20 ms

The **battery warning \bar{W}** reports that the battery capacity has fallen below 10%. The ready signal also resets the battery warning.

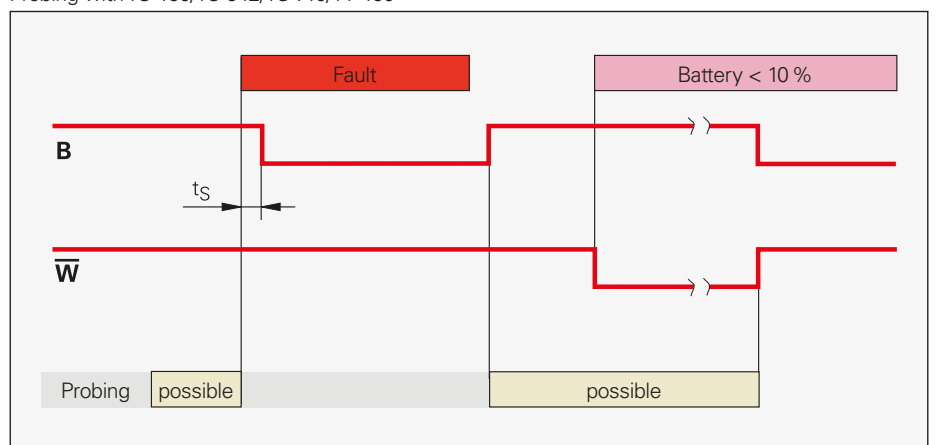

Behavior during disturbance and battery warning

HTL signal levels

R
 $U_H = (10\text{ V} \dots 30\text{ V})$ at $I_H \leq 4\text{ mA}$
 $U_L \leq 2\text{ V}$ at $-I_L \leq 0.1\text{ mA}$

$B/\bar{S}/\bar{W}$

$U_H \geq (U_P - 2.2\text{ V})$ at $-I_H \leq 20\text{ mA}$
 $U_L \leq 1.8\text{ V}$ at $I_L \leq 20\text{ mA}$

TL laser systems, DA 301 TL

TL inputs

The CNC activates the laser system through three enabling lines:

The **enable transmitter 0** (ENABLE 0) signal activates or deactivates the transmitter and switches the laser beam on or off. To reduce the power loss (heat generation) to a minimum and increase service life, the laser diode is activated only during the measuring cycle.

The **receiver enabling 1** and **2** (ENABLE 1 and ENABLE 2) determine the operating mode of the laser light barrier depending on the respective measuring cycle.

Signal levels:

$U_H = 24\text{ V}$ at 15 mA

TL outputs

The TL laser systems provide the following output signals:

After the transmitter and receiver are enabled, the laser system provides the information **"Laser OK"** if the luminance at the receiver is at least 75 % of the maximum.

Two output signals are generated when the laser beam is interrupted.

The **measuring signal static STA** output switches to LOW level if the luminance at the receiver is less than 50 % (= interrupted light beam).

Do not use this output for a trigger signal. Rapidly rotating tools cause spike pulses with extremely short pulse times that cannot be evaluated by the PLC or NC.

The measuring signal dynamic DYN

output provides a 24 V pulse with a defined duration of 20 ms for every light modulation (light to dark and dark to light). This output is used for the trigger signal.

Signal levels:

$U_H = 24\text{ V}$ at 50 mA

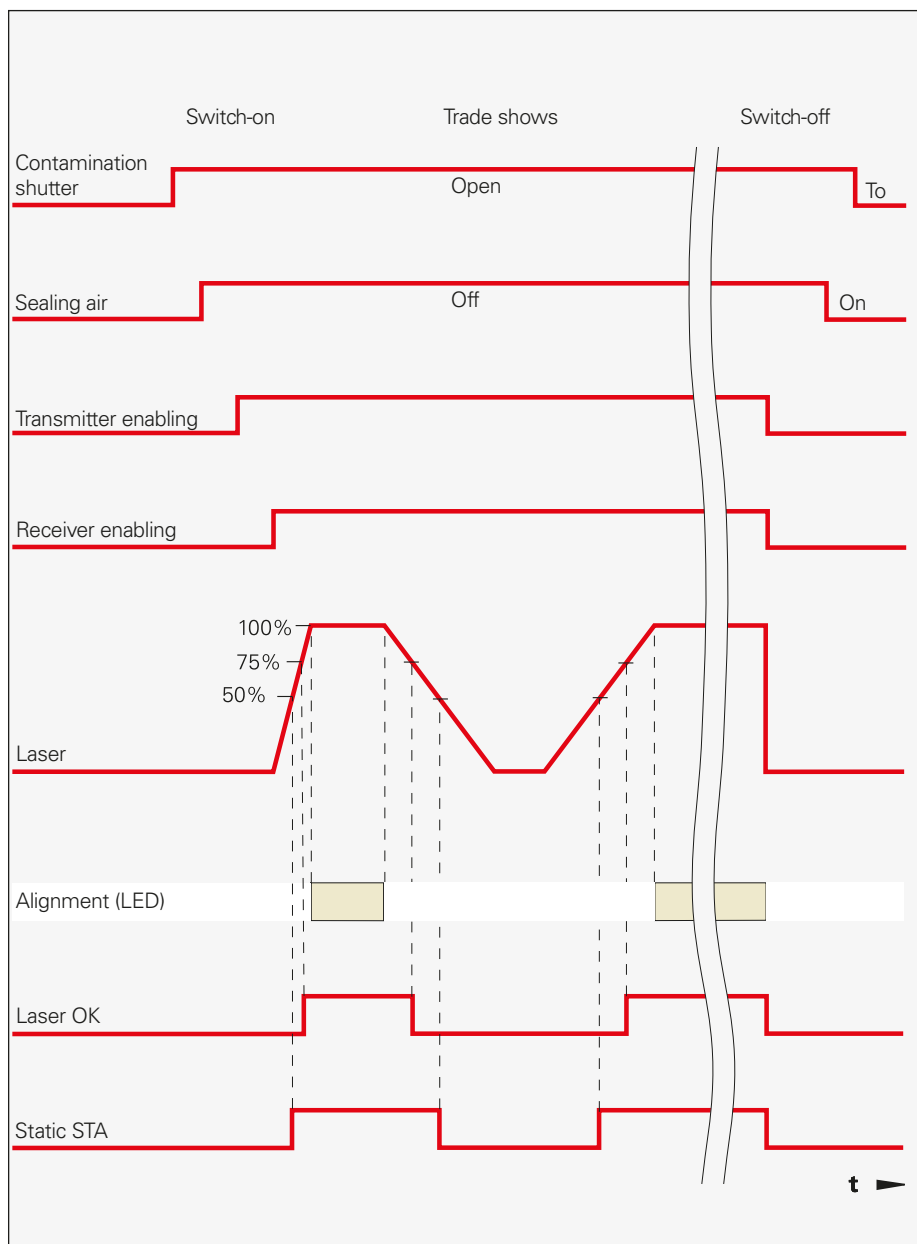

Switch-on/switch-off behavior

DA 301 TL inputs

The DA 301 TL supplies the laser systems with clean compressed air for contamination protection, for opening the seal, and for cleaning the tool. The respective **pneumatic valves** are controlled by the CNC. The cables to the CNC are included in delivery with the DA 301 TL.

Signal levels:

$U_H = 24\text{ V}$ at 71 mA

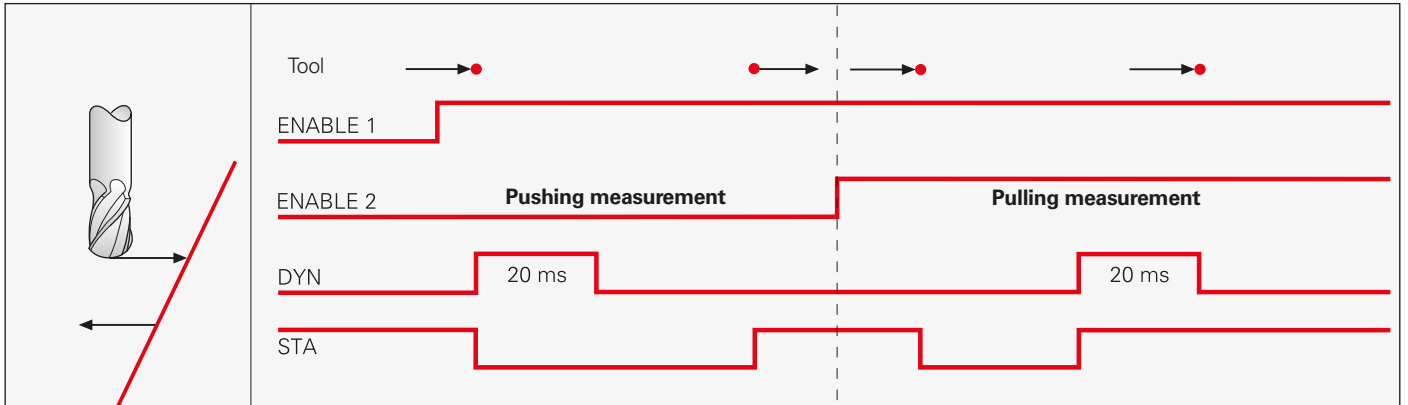

Output signals during length and radius measurement for pushing and pulling measurement

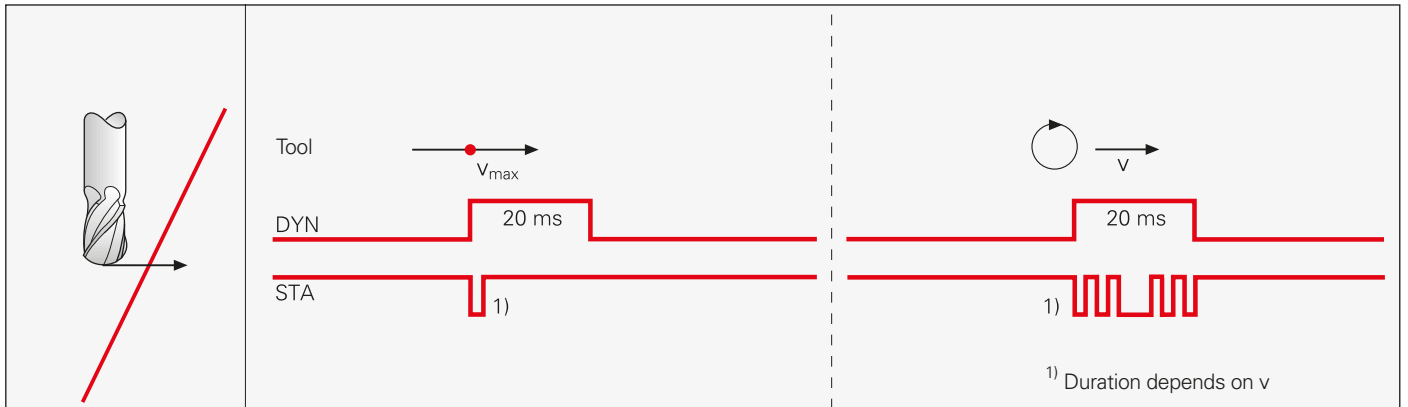

Fast axis feed rates or rotating tools can cause spike pulses in the STA signal

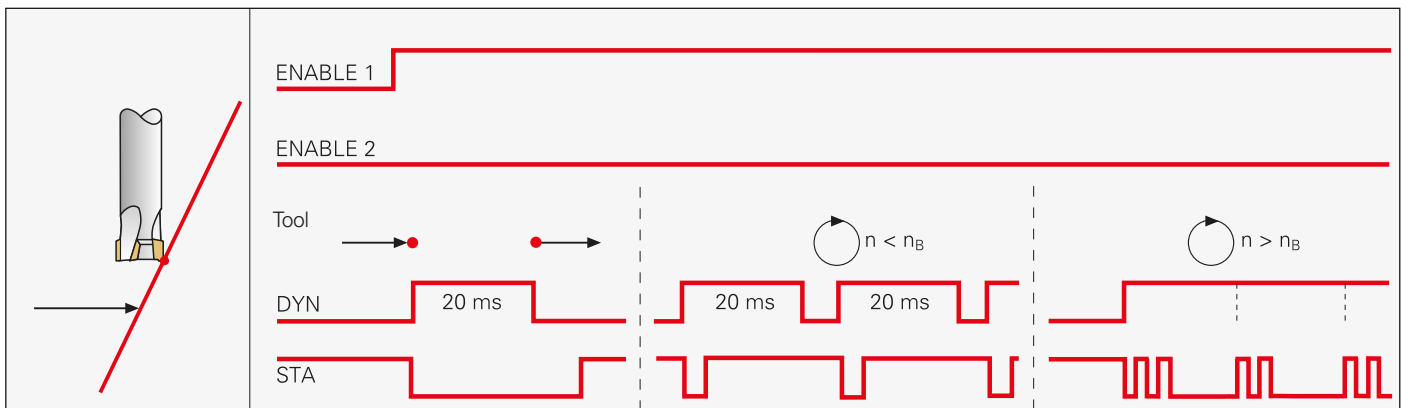

Output signals during shape inspection of individual teeth

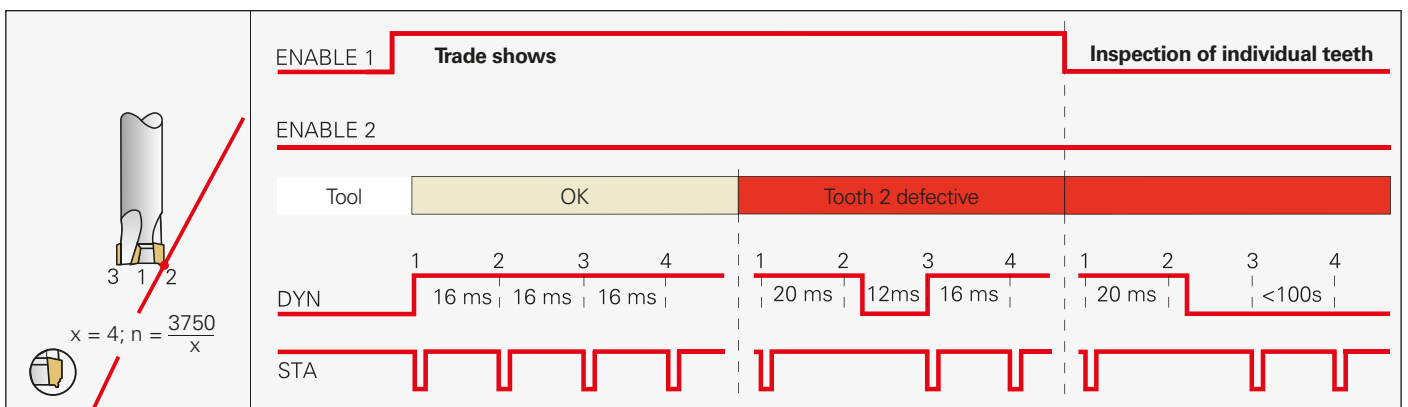

Output signals during tooth inspection in the measuring and individual tooth inspection modes

Connection to CNC controls

HEIDENHAIN touch probes feature universal interfaces that permit connection with practically all relevant CNC controls for machine tools. Where necessary, HEIDENHAIN offers UTI interface electronics and optional software packages to supplement the touch probe cycles in the control. This ensures a reliable connection and functional application of HEIDENHAIN touch probes regardless of the make of the control.

| CNC | Touch probes | Control input | Interface required | Cycles | |
|---|---|---|--|---|---|
| | | | | CNC internal | Separate software from HEIDENHAIN |
| HEIDENHAIN TNC 640 TNC 620 iTNC 530 TNC 320 TNC 128 | <i>Cable:</i> TS 248 TS 260 TT 160 <i>Radio/infrared:</i> TS 460 TT 460 Via SE 660 | <i>HSCI:</i> X112, X113 | – | Workpiece measurement <ul style="list-style-type: none"> • Workpiece alignment • Datum setting • Workpiece measurement Tool measurement <ul style="list-style-type: none"> • Length, radius • Wear, breakage • Individual teeth | – |
| Siemens 828D 840D 840D sl | | <i>Other:</i> X12, X13 | – ¹⁾ | | |
| Fanuc 0 0i 16 18 21 30 31 32 | Via SE 642, SE 540 | X121, X122 or X132 | – | Workpiece measurement <ul style="list-style-type: none"> • Workpiece alignment • Datum setting • Workpiece measurement Tool measurement <ul style="list-style-type: none"> • Length, radius • Wear, breakage | Workpiece measurement <ul style="list-style-type: none"> • Workpiece alignment • Datum setting • Workpiece measurement Tool measurement <ul style="list-style-type: none"> • Length, radius • Wear, breakage |
| Mitsubishi M70/M700 series M64/M640 series | | <i>Recommended:</i> HIGH SPEED SKIP | UTI 491 (only for connection of an SE) | – | |
| Mazak Mazatrol Fusion Mazatrol Matrix Mazatrol Smart Mazatrol Smooth X | | <i>Possible:</i> SKIP (24 V) | – | Basic cycle for <ul style="list-style-type: none"> • Setting a preset • Tool length | |
| | | SKIP (24 V) | | | |

¹⁾The UTI 240 is required if TS 460 and TT 460 are operated together.

Interface electronics for integration

To adapt the touch probe signals to the CNC control, a UTI interface unit might be required under certain circumstances. This particularly applies for connecting SE transceiver units to Fanuc controls or for retrofitting old CNC controls with a touch probe.

UTI 491

Die UTI 491 interface unit is a simple optocoupler relay. It serves to galvanically isolate the touch probes at the High Speed Skip input from Fanuc controls.

ID 802467-01



UTI 240

The UTI 240 interface unit is required when the TS and TT are to be retrofitted with a common SE on the TNC 320 or other old HEIDENHAIN controls. It distributes the TS and the TT signals to the corresponding inputs of the TNC and sets up a connection to the PLC for starting the TT and transmitting the warning signal.

ID 658883-01



UTI 150

The UTI 150 interface unit is required in order to operate the TS 150 touch probe on NC controls. It adapts the touch probe signals to the control and serves as the voltage supply for the touch probe. The touch probe status is indicated by LEDs. The UTI 150 is built into the electrical cabinet of the machine.

ID 1133534-01



UTI 150

UTI 660

The UTI 660 interface unit is needed in order to connect the EnDat versions of the TS 460 and TT 460 touch probes with the NC control. Up to four TS 460 and four TT 460 units can be operated using the UTI 660.

ID 1169537-01



UTI 660

UTI 192

The UTI 192 interface unit is used when additional adaptations are required that cannot be implemented in the CNC control, such as the logical gating of signals or the automatic starting of a touch probe, etc. The UTI 192 is therefore usually used for retrofitting touch probes (see the product overview *Touch Probes for Retrofitting on Machine Tools*).

ID 579092-01



Connecting elements and cables

General information

Connector insulated: Connecting element with coupling ring, available with male or female contacts (see symbols).

Symbols

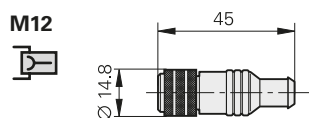

M12 right-angle connector

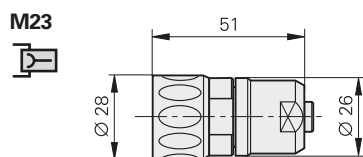
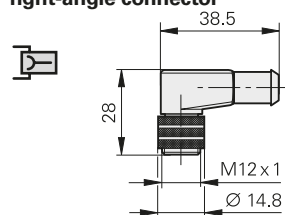

Coupling insulated: Connecting element with outside thread, available with male or female contacts (see Symbols).

Symbols

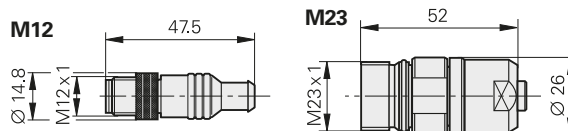

Mounted coupling with flange

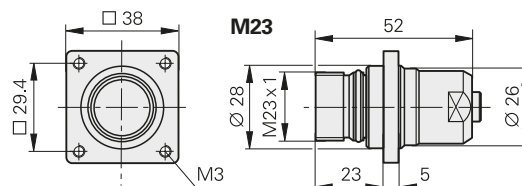

Flange socket: With external thread; permanently mounted on a housing, available with male or female contacts.

Symbols

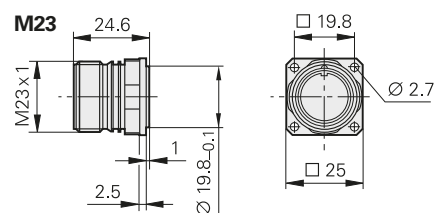

D-sub connector for HEIDENHAIN controls, counters, and IK absolute value cards.

Symbols

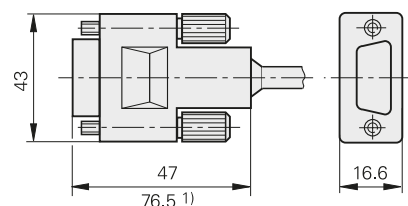

¹⁾ Interface electronics integrated in connector

The **pin numbering** on connectors is in the direction opposite to those on couplings or flange sockets, regardless of whether the connecting elements have

male contacts or



female contacts.



When engaged, the connections provide **protection** to IP67 (D-sub connector: IP50; EN 60529). When not engaged, there is no protection.

Accessory for flange sockets M23 mounted couplings

Threaded metal dust cap

ID 219926-01

Accessory for M12 connecting element

Insulation spacer

ID 596495-01

Quick disconnect: Compact connector with push/pull lock

Symbol

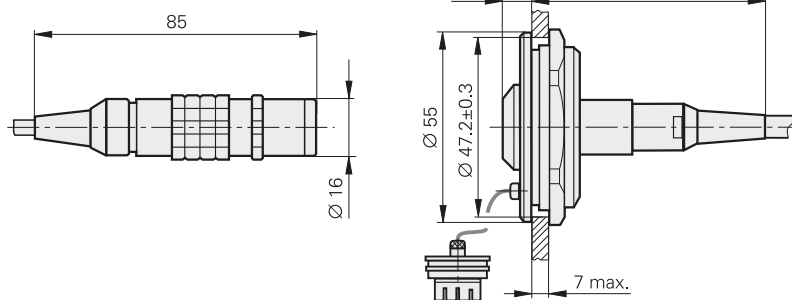

You will find information on cable routing and bend radii under *General electrical information* in the catalog *Interfaces of HEIDENHAIN encoders*.

TS, TT, and SE pin layouts

SE 660, SE 642

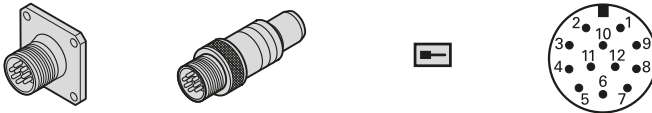
| 12-pin flange socket or coupling M12 | | | | | | | | | | | | |
|--|----------------------|-----------------|--------------|--------------|--------------|--------------|----------|-----------------------------|-----------------------------|----------|----------|----------|
|  | | | | | | | | | | | | |
| | Voltage supply | | Signals | | | | | | | | | |
| | 1 | 12 | 11 | 5 | 2 | 10 | 3 | 4 | 6 | 9 | 7 | 8 |
| | U_P | 0V | R(TS) | R(TT) | B(TS) | B(TT) | S | \bar{S} | \bar{W} | / | / | / |
| | Brown/ Green | White/ Green | Blue | White | Green | Brown | Gray | Pink | Violet | Yellow | Red | Black |

External shield is on housing. Unused pins or wires must not be engaged.

U_P = Voltage supply; **R** = Start signal; **B** = Ready signal; **S, \bar{S}** = Trigger signal; **\bar{W}** = Battery warning

SE 540 (adapter cable)

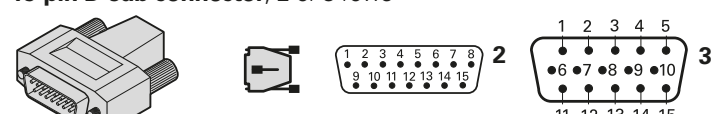
| 7-pin coupling, M23 | | | | 15-pin D-sub connector, 2 or 3 rows | | | |
|--|----------------------|-----------|------------------------|---|----------|-----------------------------|-----------------------------|
|  | | | |  | | | |
| | Voltage supply | | | Signals | | | |
| | 2 | 1 | 7 | 3 | 5 | 4 | 6 |
| 2 | 5 | 8 | 1 | 4 | 3 | 10 | 7 |
| 3 | 10 | 9 | / | 6 | 3 | 2 | 4 |
| | U_P | 0V | Internal shield | R | B | \bar{S} | \bar{W} |
| | Brown | White | White/Brown | Yellow | Gray | Green | Blue |

External shield is on housing. Unused pins or wires must not be engaged.

U_P = Voltage supply; **R** = Start signal; **B** = Ready signal; **\bar{S}** = Trigger signal; **\bar{W}** = Battery warning

TS 150, TS 248, TS 260, TS 160

| 8-pin connector, M12 | | | | | | | | |
|--|----------------------|-----------|----------|-----------------------------|----------|-------------------|-------------------|-------------------|
|  | | | | | | | | |
| | Voltage supply | | Signals | | | | | |
| | 2 | 7 | 3 | 4 | 1 | 5 | 6 | 8 |
| | U_P | 0V | S | \bar{S} | B | Trigger NO | Trigger NC | Trigger 0V |
| | Blue | Violet | Gray | Pink | White | White/Green | Yellow | Brown/Green |

External shield is on housing. Unused pins or wires must not be engaged.

U_P = Voltage supply; **B** = Ready signal; **S, \bar{S}** = Trigger signal;

Trigger = Floating switching outputs (NC = normally closed, NO = normally open)

Please note: Important information on electrical connection, voltage supply, and cable routing is available under *General electrical information* in the *Interfaces of HEIDENHAIN Encoders* brochure.

SE 660, SE 642, and SE 540 connecting cables

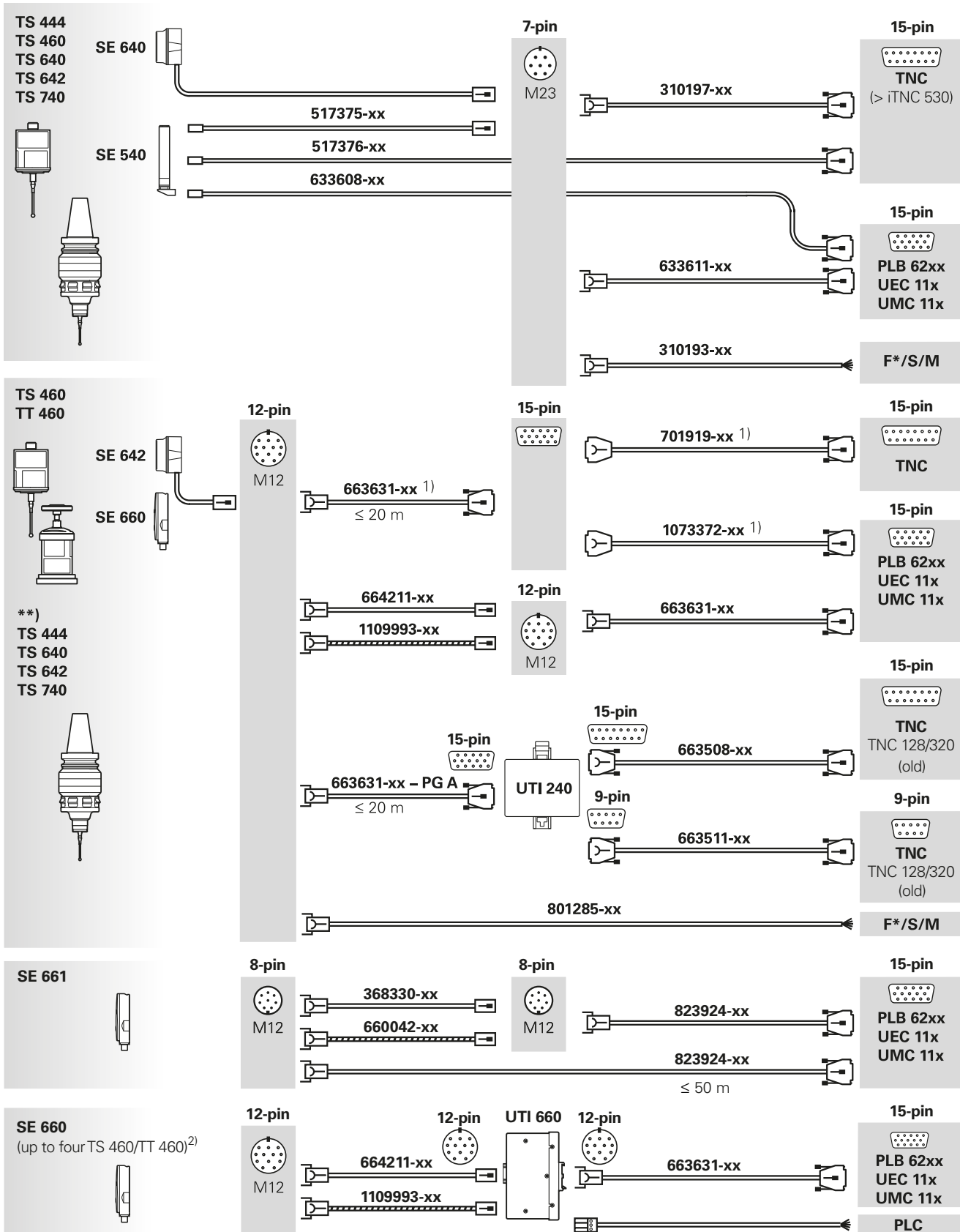

¹⁾ If total cable length is greater than 20 m, use ID 663631-xx for the first max. 10 m, and for the remaining length use ID 701919-xx/1073372-xx.
²⁾ Depending on the version

**) TS 444/64x/740 not possible in connection with SE 660
 F*/S/M = Fanuc/Siemens/Mitsubishi/Mazak, F* Fanuc High Speed Skip via UTI 491

TS 248, TS 150, TS 260, and TT 160 connecting cables

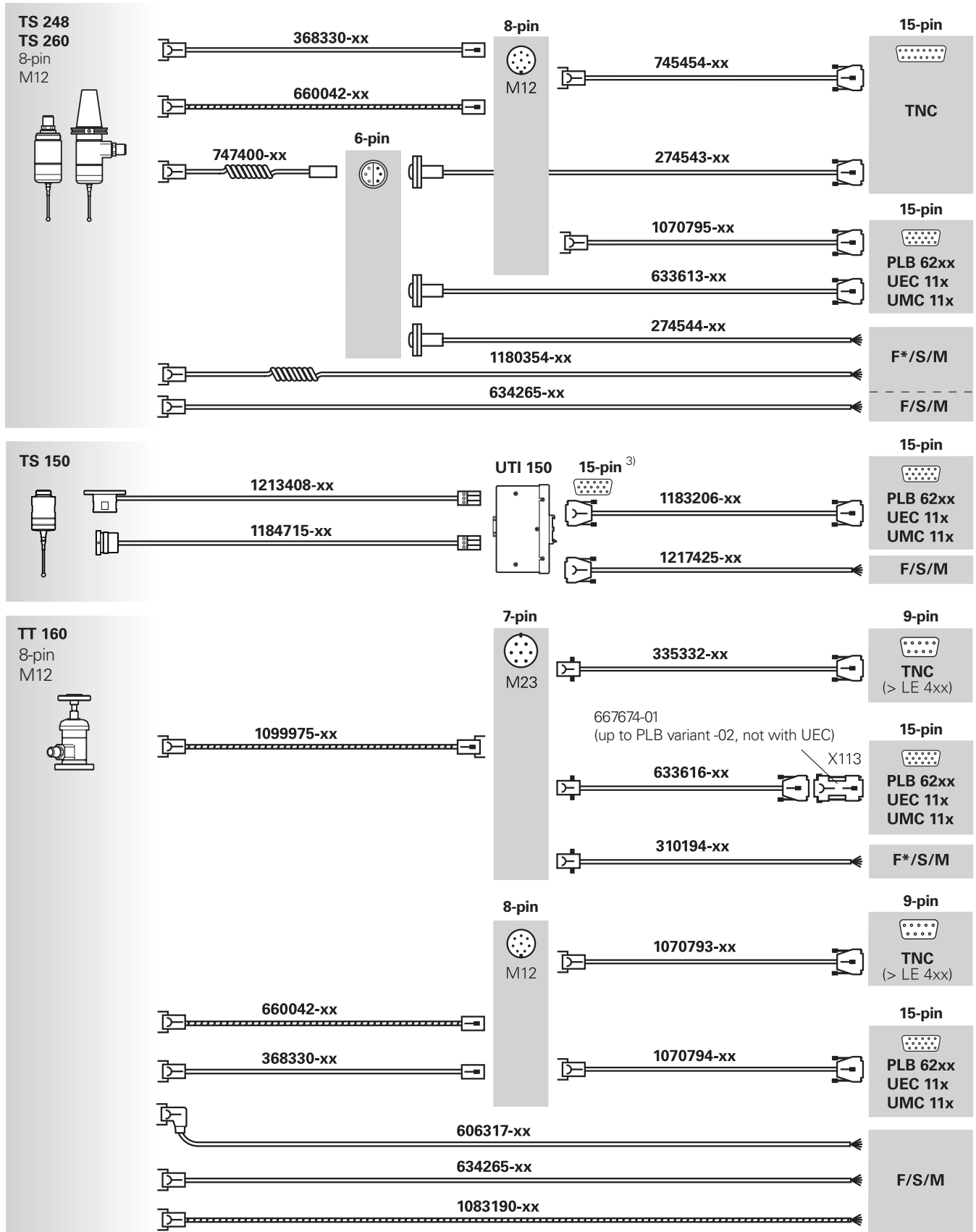

F/S/M = Fanuc/Siemens/Mitsubishi/Mazak, F*Fanuc High Speed Skip via UTI 491

Pin layouts and adapter cables

TL, DA 301 TL

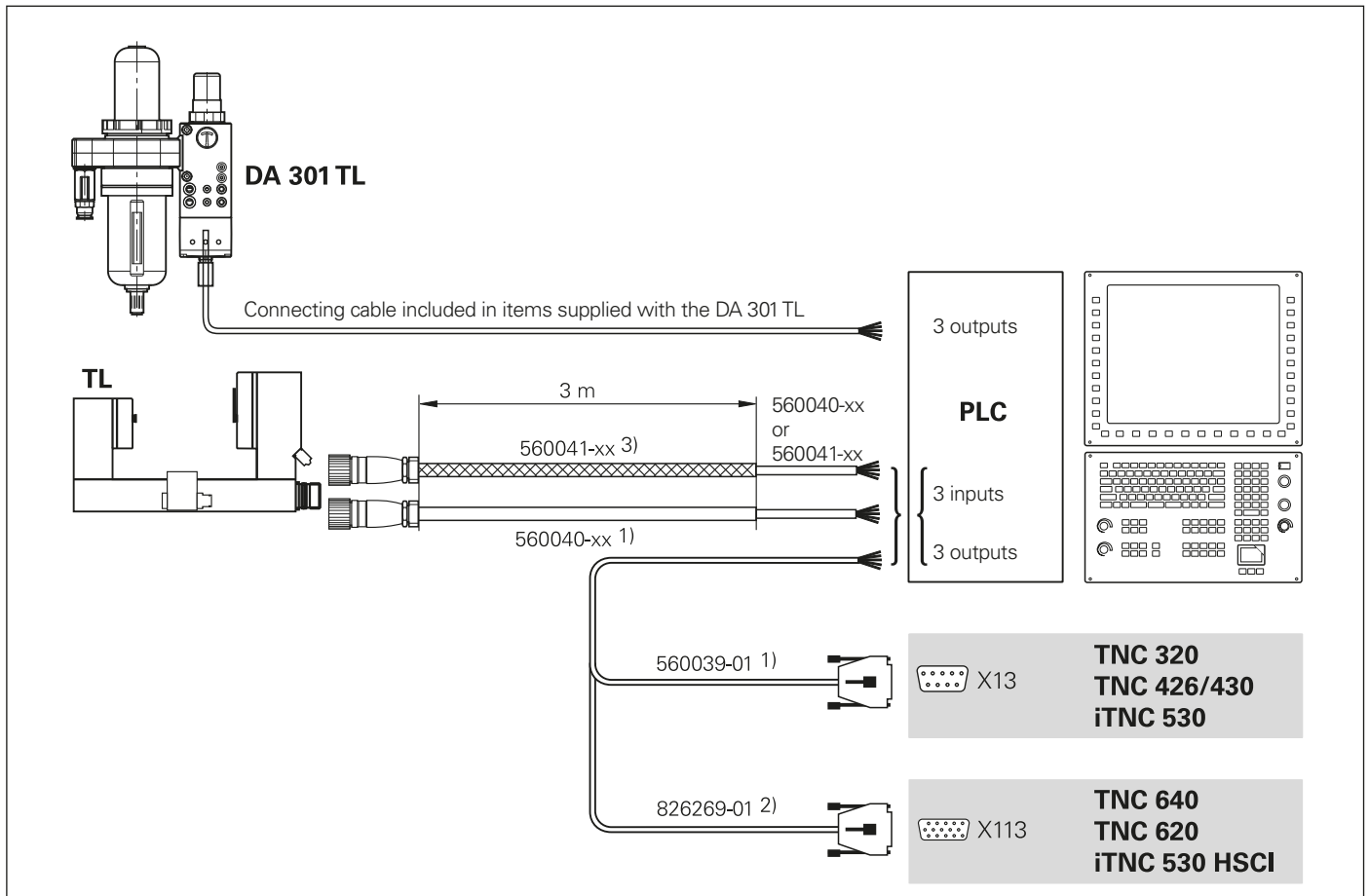

Adapter cable Ø 14 mm/Ø 6.5 mm
With one M23 connector (female), 12-pin
 Smallest permissible bending radius
 60 mm, suitable for use in drag chains

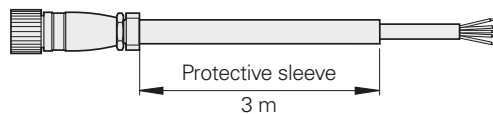

With PUR protective sleeve
 ID 560040-xx

Adapter cable length 5 m
With one D-sub connector (male), 9-pin
 Integrated interface for TNC 320/426/430,
 iTNC 530

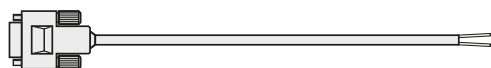





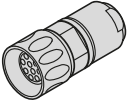

ID 560039-01

With one D-sub connector (male), 15-pin,
 3-row
 Integrated interface for TNC 620/640, iTNC
 530 HSCI

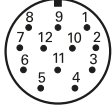
ID 826269-01

TL laser system

| | | | | | | | | |
|---|----------------|-----------|-----------------|-----------------|-----------------|------------|------------|-----------------|
| 12-pin connector M23    | | | | | | | | |
| | Voltage supply | | Signals | | | Outputs | | |
|  | 2 | 1 | 4 | 12 | 6 | 3 | 5 | 7 |
| | 24V | 0V | ENABLE 0 | ENABLE 1 | ENABLE 2 | DYN | STA | LASER OK |
|  | Brown | White | Yellow | Pink | Violet | Green | Gray | Blue |

| | | |
|---|----------------|------------|
| 9-pin D-sub connector | | |
| | Channel inputs | |
| | 0V | DYN |
|  | White | Brown |

| | | | |
|---|-----------------------|-----------|-----------------------------|
| 3-pin connector | | | |
| | Outputs | | |
| | Trigger signal | 0V | Protective conductor |
|  | Black | Black | Yellow/Green |

HEIDENHAIN

DR. JOHANNES HEIDENHAIN GmbH

Dr.-Johannes-Heidenhain-Straße 5

83301 Traunreut, Germany

☎ +49 8669 31-0

FAX +49 8669 32-5061

E-mail: info@heidenhain.de

www.heidenhain.de

Vollständige und weitere Adressen siehe www.heidenhain.de
For complete and further addresses see www.heidenhain.de

| | | | | | |
|-----------|--|-----------|--|-----------|---|
| DE | HEIDENHAIN Vertrieb Deutschland 83301 Traunreut, Deutschland ☎ 08669 31-3132 FAX 08669 32-3132 E-Mail: hd@heidenhain.de | ES | FARRESA ELECTRONICA S.A. 08028 Barcelona, Spain www.farresa.es | PH | MACHINEBANKS' CORPORATION Quezon City, Philippines 1113 E-mail: info@machinebanks.com |
| | HEIDENHAIN Technisches Büro Nord 12681 Berlin, Deutschland ☎ 030 54705-240 | FI | HEIDENHAIN Scandinavia AB 01740 Vantaa, Finland www.heidenhain.fi | PL | APS 02-384 Warszawa, Poland www.heidenhain.pl |
| | HEIDENHAIN Technisches Büro Mitte 07751 Jena, Deutschland ☎ 03641 4728-250 | FR | HEIDENHAIN FRANCE sarl 92310 Sèvres, France www.heidenhain.fr | PT | FARRESA ELECTRÓNICA, LDA. 4470 - 177 Maia, Portugal www.farresa.pt |
| | HEIDENHAIN Technisches Büro West 44379 Dortmund, Deutschland ☎ 0231 618083-0 | GB | HEIDENHAIN (G.B.) Limited Burgess Hill RH15 9RD, United Kingdom www.heidenhain.co.uk | RO | HEIDENHAIN Reprezentantă Romania Braşov, 500407, Romania www.heidenhain.ro |
| | HEIDENHAIN Technisches Büro Südwest 70771 Leinfelden-Echterdingen, Deutschland ☎ 0711 993395-0 | GR | MB Milionis Vassilis 17341 Athens, Greece www.heidenhain.gr | RS | Serbia → BG |
| | HEIDENHAIN Technisches Büro Südost 83301 Traunreut, Deutschland ☎ 08669 31-1345 | HK | HEIDENHAIN LTD Kowloon, Hong Kong E-mail: sales@heidenhain.com.hk | RU | OOO HEIDENHAIN 115172 Moscow, Russia www.heidenhain.ru |
| | | HR | Croatia → SL | SE | HEIDENHAIN Scandinavia AB 12739 Skärholmen, Sweden www.heidenhain.se |
| AR | NAKASE SRL. B1653AOX Villa Ballester, Argentina www.heidenhain.com.ar | HU | HEIDENHAIN Kereskedelmi Képviselet 1239 Budapest, Hungary www.heidenhain.hu | SG | HEIDENHAIN PACIFIC PTE LTD Singapore 408593 www.heidenhain.com.sg |
| AT | HEIDENHAIN Techn. Büro Österreich 83301 Traunreut, Germany www.heidenhain.de | ID | PT Servitama Era Toolsindo Jakarta 13930, Indonesia E-mail: ptset@group.gts.co.id | SK | KOPRETINA TN s.r.o. 91101 Trenčín, Slovakia www.kopretina.sk |
| AU | FCR MOTION TECHNOLOGY PTY LTD Laverton North Victoria 3026, Australia E-mail: sales@fcrmotion.com | IL | NEUMO VARGUS MARKETING LTD. Holon, 58859, Israel E-mail: neumo@neumo-vargus.co.il | SL | NAVO d.o.o. 2000 Maribor, Slovenia www.heidenhain.si |
| BE | HEIDENHAIN NV/SA 1760 Roosdaal, Belgium www.heidenhain.be | IN | HEIDENHAIN Optics & Electronics India Private Limited Chetpet, Chennai 600 031, India www.heidenhain.in | TH | HEIDENHAIN (THAILAND) LTD Bangkok 10250, Thailand www.heidenhain.co.th |
| BG | ESD Bulgaria Ltd. Sofia 1172, Bulgaria www.esd.bg | IT | HEIDENHAIN ITALIANA S.r.l. 20128 Milano, Italy www.heidenhain.it | TR | T&M Mühendislik San. ve Tic. LTD. ŞTİ. 34775 Y. Dudullu – Umraniye-Istanbul, Turkey www.heidenhain.com.tr |
| BR | DIADUR Indústria e Comércio Ltda. 04763-070 – São Paulo – SP, Brazil www.heidenhain.com.br | JP | HEIDENHAIN K.K. Tokyo 102-0083, Japan www.heidenhain.co.jp | TW | HEIDENHAIN Co., Ltd. Taichung 40768, Taiwan R.O.C. www.heidenhain.com.tw |
| BY | GERTNER Service GmbH 220026 Minsk, Belarus www.heidenhain.by | KR | HEIDENHAIN Korea LTD. Gasan-Dong, Seoul, Korea 153-782 www.heidenhain.co.kr | UA | Gertner Service GmbH Büro Kiev 01133 Kiev, Ukraine www.heidenhain.ua |
| CA | HEIDENHAIN CORPORATION Mississauga, Ontario L5T2N2, Canada www.heidenhain.com | MX | HEIDENHAIN CORPORATION MEXICO 20290 Aguascalientes, AGS., Mexico E-mail: info@heidenhain.com | US | HEIDENHAIN CORPORATION Schaumburg, IL 60173-5337, USA www.heidenhain.com |
| CH | HEIDENHAIN (SCHWEIZ) AG 8603 Schwerzenbach, Switzerland www.heidenhain.ch | MY | ISOSERVE SDN. BHD. 43200 Balakong, Selangor E-mail: sales@isoserve.com.my | VE | Maquinaria Diekmann S.A. Caracas, 1040-A, Venezuela E-mail: purchase@diekmann.com.ve |
| CN | DR. JOHANNES HEIDENHAIN (CHINA) Co., Ltd. Beijing 101312, China www.heidenhain.com.cn | NL | HEIDENHAIN NEDERLAND B.V. 6716 BM Ede, Netherlands www.heidenhain.nl | VN | AMS Co. Ltd HCM City, Vietnam E-mail: davidgoh@amsvn.com |
| CZ | HEIDENHAIN s.r.o. 102 00 Praha 10, Czech Republic www.heidenhain.cz | NO | HEIDENHAIN Scandinavia AB 7300 Orkanger, Norway www.heidenhain.no | ZA | MAFEMA SALES SERVICES C.C. Midrand 1685, South Africa www.heidenhain.co.za |
| DK | TPTEKNIK A/S 2670 Greve, Denmark www.tp-gruppen.dk | NZ | Llama ENGINEERING Ltd 5012 Wellington, New Zealand E-mail: info@llamaengineering.co.nz | | |

